

# Mercury™ 3500Si Smart Encoder Systems

## High Speed Serial Word Output with Resolution to 5 nanometers\*

Reflective Linear and Rotary Encoder Systems

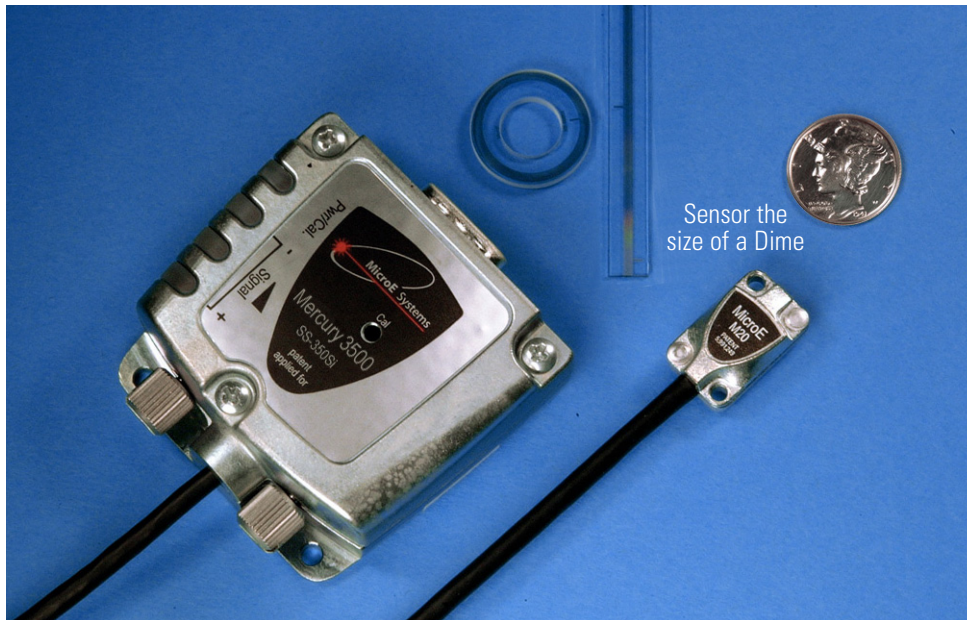

### Resolution

Linear: 5µm to 0.005µm\*  
Rotary: 6,600 to 67.1 M CPR

### Accuracy

Linear: ± 1µm available  
± 3µm to ± 5µm standard  
Rotary: Up to ± 2.1 arc-sec

### Output

High Speed Serial Word in SPI Format

The New Mercury 3500Si encoder represents the next level of encoder performance. With high speed operation, smallest sensor size, easiest alignment, and superior noise immunity, the M3500Si delivers Best-in-Class performance.

### Imagine what you can do with this!

The new Mercury 3500Si can reduce the cost and size of your system, and improve its performance all at once! MicroE Systems' Mercury 3500Si kit encoders are smaller, higher performance, faster to install, and easier to set up and align than any other encoder. The tiny sensor fits into very tight spaces and works in both linear and rotary applications. The industry-standard SPI serial data interface is ideal for encoders and produces extremely high resolution at high motion speed - up to 30X faster than A-quadrant-B encoders. The SPI standard is supported by many DSP chip manufacturers and is easy to implement in your OEM controller design.

### New features

- New metal enclosure for SmartPrecision™ electronics
- Best-in-Class noise immunity for harsh environments
- Shorter length for smaller, tighter cabinets
- Frame mounting compatible for easy installation
- Robust metal housing with easy access locking screws
- Double shielded long life cable
- CE compliance pending

### Standard features

- Smallest sensor- 1/3 the size of other encoders
- Revolutionary bolt-in alignment for many applications
- Advanced SmartPrecision electronics built into shielded D-sub connector
- Serial Word output with interpolation in binary steps for resolutions to 0.005µm\* (linear); 67.1M CPR (rotary)
- LED set up indicators for sensor alignment and index location
- Bi-directional index signal is repeatable to encoder resolution

### Table of Contents

<b>System &amp; Sensor</b>	<b>pg 1-5</b>
<b>SmartPrecision Electronics</b>	<b>pg 6-7</b>
<b>SmartPrecision Software</b>	<b>pg 8</b>
<b>Scales</b>	<b>pg 9-10</b>
<b>Ordering Information</b>	<b>pg 10</b>

### Optional features:

- Glass scale length or diameter
- Linear lengths from 5mm to 2m
- Rotary diameters from 12mm to 108mm
- Cable length of 0.5m, 1m, 2m, or custom
- SmartPrecision Software



\* Resolution values shown are approximate - see p. 4 for exact values.

# System Configurations

## Standard and Optional Equipment

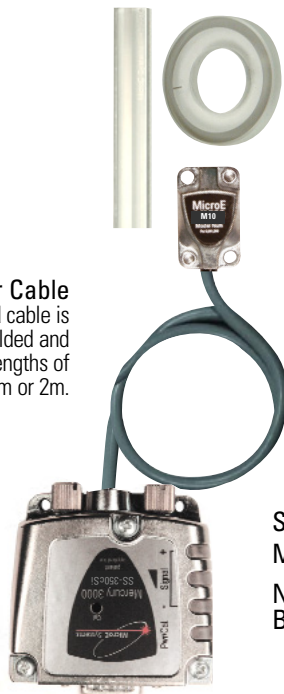

**Sensor Cable**  
The standard cable is double shielded and available in lengths of 0.5m, 1m or 2m.

**Encoder Sensor**  
Same for linear and rotary scales.

**SmartPrecision™ Electronics Module**  
New Metal Enclosure Provides Best-in-Class Noise Immunity

A 15 pin high density D-sub connector mates to the customer controller.

### M3500Si Smart Encoder Systems Standard Equipment



#### RS 232 Interface Adapter

The adapter provides connections to a PC, the encoder system and the controller.

### M3500Si Optional Equipment

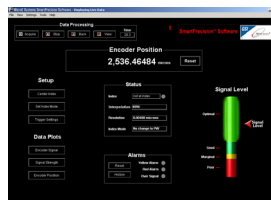

#### SmartPrecision™ Software

The software module enables all programmable and diagnostic features plus displays encoder output and signal strength. See page 8 for details.

# Broader Alignment Tolerances, Increased Standoff Clearance, Smallest Sensor and More

## Why Mercury Encoders Make It Easier To Design High Performance Into Your Equipment

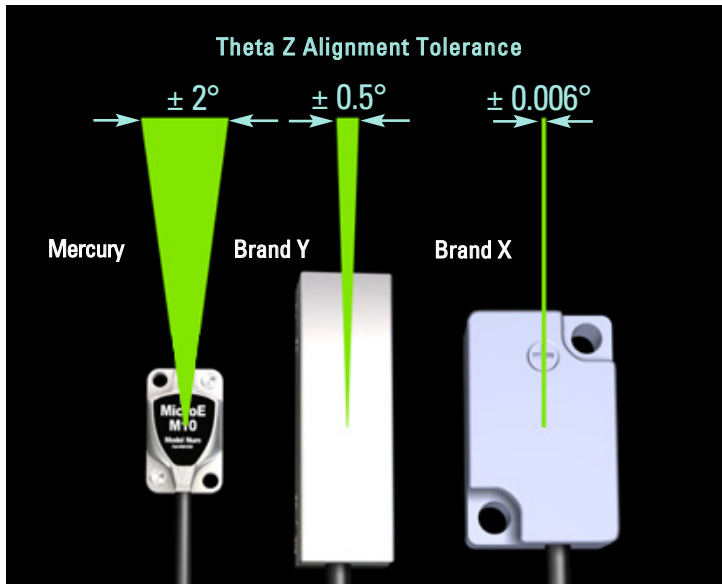

### Eliminate the Frustration of Touchy Encoder Alignment

#### Mercury Solves this Problem for Good

Fussy alignment is no longer a concern. With Mercury's patented PurePrecision™ optics, advanced SmartPrecision™ electronics and LED alignment indicators, you can push the sensor against your reference surface, tighten the screws and you're finished. Try that with brand X or Y.

This performance is possible thanks to relaxed alignment tolerances, particularly in the theta Z axis. Mercury offers a ± 2° sweet spot— that's a 300% improvement over the best competitive encoder. And that will result in dramatic savings in manufacturing costs.

No other commercially available encoder is easier to align, easier to use, or easier to integrate into your designs.

### Alignment Tolerance Comparison\*\*

	Mercury*	Brand X	Brand Y	Mercury vs. Best Competitor
Z Standoff	± 0.15mm	± 0.1mm	± 0.1mm	Mercury is 50% better
Y	± 0.20mm for linear ± 0.10mm for rotary ≥19mm dia.	± 0.1mm	unspecified	Mercury is 100% better
theta X	± 1.0°	unspecified	± 1.0°	
theta Y	± 2.0°	± 0.1°	± 1.0°	Mercury is 100% better
theta Z	± 2.0°	± 0.006°	± 0.5°	Mercury is 300% better

\*Measured at a constant temperature for one axis at a time with all other axes at their ideal positions.

\*\*Based on published specifications

### Mercury Can Reduce System Size and Cost

Mercury's sensor height is 44% shorter than competitive encoders, making it easy to fit into your design. This reduction can also cut total system weight and cost by allowing the use of smaller motors and stages. Safe system operation is also enhanced thanks to Mercury's generous standoff clearance— 200% greater than other encoders. And its standoff tolerance is 50% greater than the best alternative.

This significantly relaxes mechanical system tolerances, while reducing system costs.

### Mechanical Dimension Comparison\*\*

	Mercury	Brand X	Brand Y	Mercury vs. Best Competitor
Sensor Z height	8.4mm	23mm	15mm	44% better
Standoff clearance	2.4mm	0.5mm	0.8mm	200% better
Standoff tolerance	± 0.15mm	± 0.1mm	± 0.1mm	50% better
System height	11.7mm	28.5mm	15.8mm	26% better

\*\*Based on published specifications

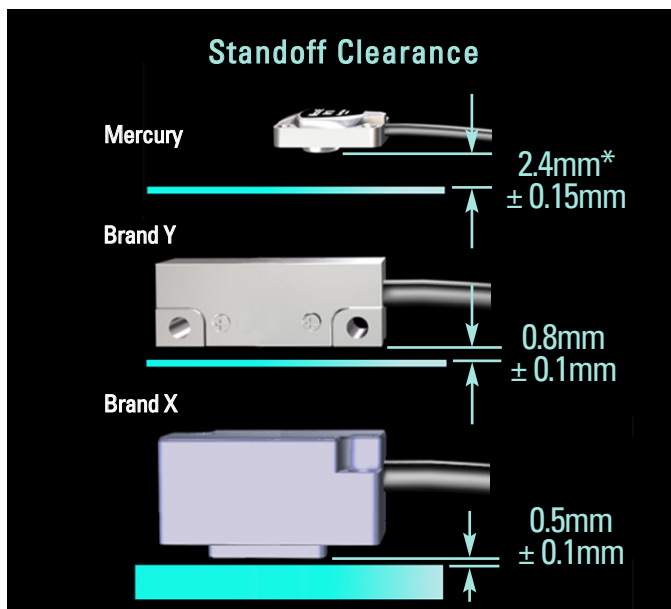

\* Dimensions shown illustrate encoder system standoff clearance; see Mercury Encoder Interface Drawings for correct design reference surfaces.

# System Specifications

## Resolution and Maximum Speed

Mercury 3500Si systems have interpolation from x4 to x4096 in binary steps. Below is a table of values. Unlike A-quadrant encoders, the M3500Si's resolution does not drop off with speed. For interpolation in integer steps consider the M3500 encoder.

### Linear - 20µm grating pitch

Interpolation	Resolution	Maximum Speed
x4	5.000 µm/count	7200mm/s
x8	2.500 µm/count	7200mm/s
x16	1.250 µm/count	7200mm/s
x32	0.6250 µm/count	7200mm/s
x64	0.3125 µm/count	7200mm/s
x128	0.15625 µm/count	7200mm/s
x256	0.078125 µm/count	7200mm/s
x512	0.0390625 µm/count	7200mm/s
x1024	0.01953125 µm/count	7200mm/s
x2048	0.009765625 µm/count	7200mm/s
x4096	0.0048828125 µm/count	7200mm/s

To calculate desired linear interpolation multiplier, use the following equation  

$$\text{Interpolation Multiplier} = \text{Grating Period (20}\mu\text{m)} / \text{Desired Resolution (}\mu\text{m/count)}$$

### Rotary - 20µm grating pitch

Rotary Glass Scale Diameter	Fundamental Resolution	Interpolation				
		x4	x256	x1024	x4096	
0.472" [12.00mm]	1650 CPR	Note: The range of available values is x4 to x1024 in binary steps; example values below.				
		interpolated resolution (CPR)	6,600	422,400	1,689,600	6,758,400
		interpolated resolution (arc-sec/count)*	196.4	3.08	0.767	0.192
		interpolated resolution (µrad/count)*	952	14.86	3.79	0.930
		maximum speed (RPM)	13090	13090	13090	13090
0.750" [19.05mm]	2500 CPR	interpolated resolution (CPR)	10,000	640,000	2,560,000	10,240,000
		interpolated resolution (arc-sec/count)*	129.6	2.03	0.506	0.126
		interpolated resolution (µrad/count)*	628.3	9.8	2.5	0.613
		maximum speed (RPM)	8640	8640	8640	8640
		1.250" [31.75mm]	4096 CPR	interpolated resolution (CPR)	16,384	1,048,576
interpolated resolution (arc-sec/count)*	79.1			1.24	0.309	0.077
interpolated resolution (µrad/count)*	383.5			6.0	1.5	0.0374
maximum speed (RPM)	5273			5273	5273	5273
2.250" [57.15mm]	8192 CPR			interpolated resolution (CPR)	32,768	2,097,152
		interpolated resolution (arc-sec/count)*	39.6	0.618	0.154	0.038
		interpolated resolution (µrad/count)*	191.7	3.0	0.7	0.187
		maximum speed (RPM)	2637	2637	2637	2637
		4.250" [107.95mm]	16384 CPR	interpolated resolution (CPR)	65,636	4,194,304
interpolated resolution (arc-sec/count)*	19.7			0.309	0.0772	0.019
interpolated resolution (µrad/count)*	95.9			1.5	0.4	0.093
maximum speed (RPM)	1318			1318	1318	1318

\* Resolution values shown are approximate. To calculate exact resolution values, convert from CPR (Counts Per Revolution) to the desired units.  
 All Specifications are subject to change. All data is accurate to the best of our knowledge. MicroE Systems is not responsible for errors.

# System Specifications

## System

Grating Period	20µm
Signal Period	20µm
System Resolution	5µm - 0.004882µm in binary interpolation steps.
Linear accuracy*	
Interpolation accuracy:	Better than ± 0.12µm over any 20µm movement
Long-travel accuracy:	±1µm accuracy available - consult MicroE Better than ± 3µm for scales up to 130mm Better than ±5µm for scales 155mm to 1m Better than ±5µm per meter for scales 1m or more

\*Maximum peak to peak error over the specified movement when compared to a NIST-traceable laser interferometer standard, used at room temperature and with MicroE interpolation electronics.

Rotary Accuracy*	Scale O.D.	Microradians	Arc-Seconds
	12.00mm	±100	±21
	19.05mm	±63	±13
	31.75mm	±38	±7.8
	57.15mm	±19	±3.9
	107.95mm	±10	±2.1

\*Based on ideal scale mounting concentricity

## Sensor Size

W:	12.70mm	0.500"
L:	20.57mm	0.810"
H:	8.38mm	0.330"

## Operating and Electrical Specifications

Power Supply	5VDC ±5% @ 330mA (30mA for sensor)
Temperature	
Operating:	0 to 70°C
Storage:	-20 to 70°C
Humidity:	10 - 90% RH non-condensing
EMI:	CE compliance pending
Shock:	1500G 0.5 ms half sine (Sensor)
Sensor Weight:	5.0g (Sensor without cable)
Cable:	Double Shield. Maximum length 2m. Diameter: 3.6mm (0.142") Flex Life: 20 x 10 <sup>6</sup> cycles @ 20mm bending radius

## Mechanical Information - Sensor

### Cable Length

19.7 [500] or 39.4 [1000]  
or 78.7 [2000] ±.50 [12.7]

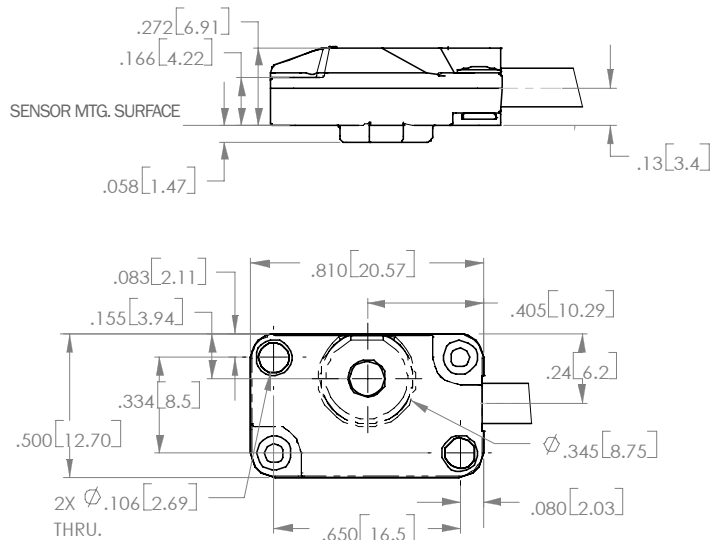
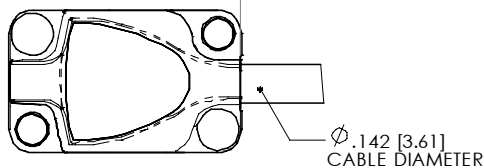

All Specifications are subject to change. All data is accurate to the best of our knowledge. MicroE Systems is not responsible for errors.



# SmartPrecision™ Electronics Module

The Mercury 3500Si encoder system includes a SmartPrecision electronics module. This compact, fully-featured signal processing system performs the following functions:

- High speed serial data output in SPI format
- Interpolation - up to 4096X
- User selectable interpolation in binary steps
- Accuracy optimization - sensor signals are automatically optimized to improve system accuracy and maximize repeatability
- Signal strength indication - red / yellow / green LEDs assist during setup and provide diagnostics at a glance
- Low Signal alarm
- Power-indicating LED
- Computer interface - for programming and data acquisition using SmartPrecision software
- Superior EMI / RFI immunity - CE compliance pending
- Mounting options - all electronics are within the EMI-shielded connector housing and can be screwed directly into a mating connector that is bulkhead mounted, or the module may be mounted to the frame of your motion system and connected using an extension cable

## High Speed Serial Interface

Motion system engineers who are optimizing their system can boost its performance by interfacing their SPI-compatible controller with the Mercury 3500Si. Its industry standard SPI high-speed serial data interface is supported by multiple DSP chip manufacturers, including TI, Motorola and Analog Devices, and provides a robust connection that is ideal for encoder interfacing. With the Mercury 3500Si, encoder position values are sent directly into the controller's DSP. Limitations of encoders with A-quadrant-B output are completely eliminated. Standard Mercury 3500Si features include:

- Very high motion speed with high encoder resolution - up to 7.2m/s movements with 0.005µm\* resolution
- 20MHz max. input clock frequency / 512kHz position word sample rate
- RS422 voltage levels are resistant to Electro Magnetic Interference and support long cable runs
- Five different modes for adjusting or zeroing serial position data relative to the index mark on the scale. Consult the Installation Manual or MicroE Applications Engineering for further details.

No Index: No changes are made to the position word at the index mark.

Mode 1: Zeros the fringe counter at the first encounter with index mark after power up.

Mode 2: Zeros the fringe counter at every encounter with index mark.

Mode 3: Zeros the fringe counter at the first encounter with index mark after power up and subtracts the index position from the calculated position making the index mark the zero position of the encoder.

Mode 4: Zeros the fringe counter at every encounter with index mark and subtracts the index position from the calculated position making the index mark the zero position of the encoder.

The index mode can be factory set or selected by the customer using SmartPrecision Software - see page 8 for software features.

\* Resolution values shown are approximate - see p. 4 for exact values.



SmartPrecision module enclosure provides "Best-in-Class" noise immunity for high noise environments.

## Mercury 3500Si Outputs:

15 pin high density Male D-sub connector

PIN	FUNCTION
1	Reserved - Do not connect
2	Serial programming interface - transmit*
3	Serial programming interface - receive*
4	Serial Data Out- (SDO-)
5	Serial Data Out+ (SDO+)
6	Reserved - Do not connect
7	Chip Select+ (n_CS+)
8	Chip Select- (n_CS-)
9	Serial Clock Feedback (SCF-)
10	Serial Clock Feedback (SCF+)
11	Alarm
12	+5VDC
13	Ground
14	Serial Clock (SCK+)
15	Serial Clock (SCK-)

\* The electronics module's serial computer programming interface can be translated to be RS-232 compatible using the MicroE SmartPrecision Computer Interface Adapter or a voltage translation circuit of your own design.

All Specifications are subject to change. All data is accurate to the best of our knowledge. MicroE Systems is not responsible for errors.

## Serial Data Format

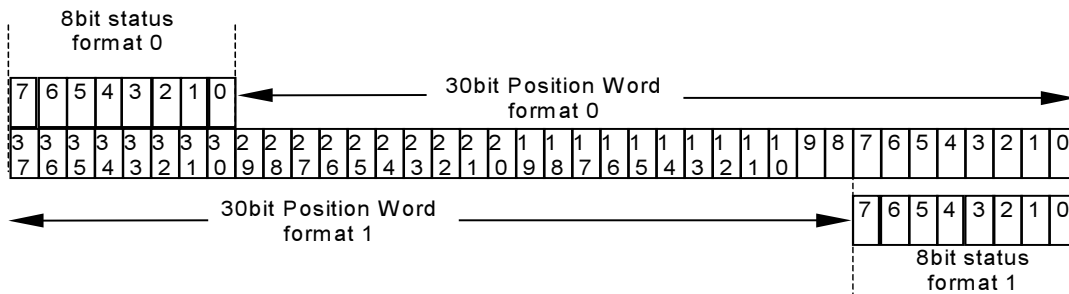

### 38 bit Data Word

The data word, which includes the status and position words, is transferred with the most significant bit (MSB) first. The data word length is up to 38 bits long. The most significant 8 bits are the status word. The next 30 bits are the position word. This position word is large enough to keep track of a measurement length of 5.24 meters. The interpolation depth of the Mercury 3500Si is X4096. If the user prefers smaller interpolation depths then fewer spiClock signal clocks can be sent to the interpolator and fewer bits will be shifted out. The status word position can be changed through the optional SmartPrecision™ software.

### Status Byte Definitions

Bit	Name	Description
0	Red Alarm	Asserted low if signal level is out of range
1	Yellow Alarm	Asserted low if signal level is near out of range
2	Index Mode	Asserted high indicates index angle in acquire mode
3	Index Window	Asserted high when encoder is within physical window
4 to 7	Reserved	

### Mechanical Information - electronics module

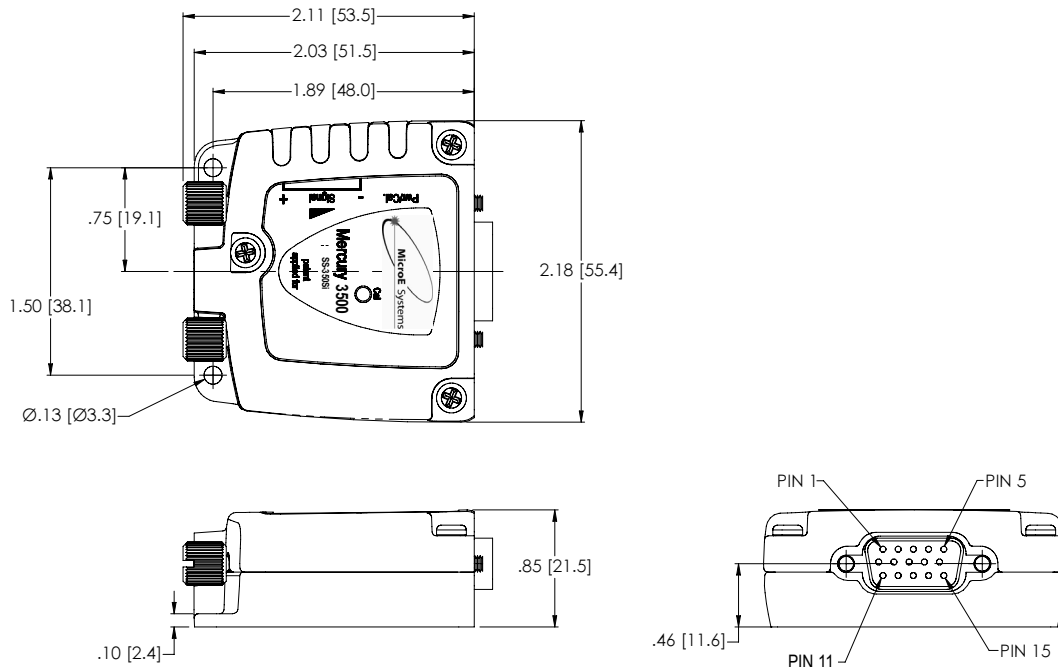

All Specifications are subject to change. All data is accurate to the best of our knowledge. MicroE Systems is not responsible for errors.

# SmartPrecision Software for Mercury 3500Si Encoder Systems



SmartPrecision Software makes Mercury the industry's easiest to use encoder. It helps you program, set up, use, and diagnose Mercury 3500Si encoders with the click of a mouse. Compatible with Windows 95, 98, ME, NT, 2000, and XP.

## Install Mercury Encoder System

- Align sensor using Signal Level display and Encoder Signal data plot
- Locate index and see when sensor is over the scale's index mark
- Verify sensor output over length of scale using the Signal Strength plot

## Monitor Mercury Encoder Operation

- Read encoder position in engineering units of your choice
- Read the encoder's hour meter to monitor system usage
- Capture alarms while system operates unattended

## Diagnose Mercury Encoder Performance

- Capture signal data and email it to MicroE for rapid diagnostic support
- Monitor alarms, view the alarm history log

## System Description

The SmartPrecision Software system includes Software on CD, a computer interface adapter, computer cable, and a power adapter.

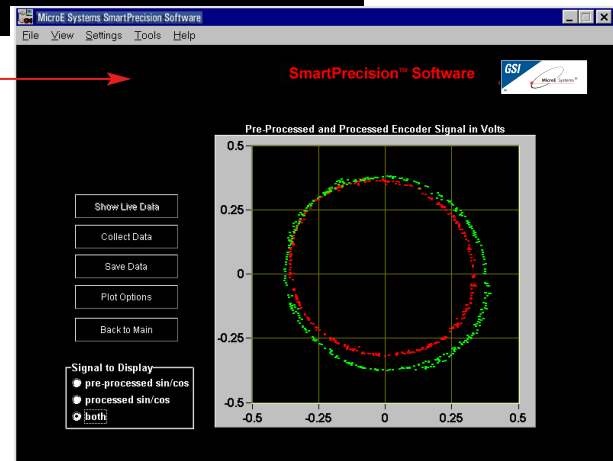

The encoder signal plot, or Lissajous plot, reveals the underlying strength and uniformity of the sensor's output.

## How to Order SmartPrecision Software

To Purchase the SmartPrecision Software system, use this Model Number: SSWA120 for 120 VAC, 60Hz US Standard 2-prong plug or SSWA220 for 220 VAC, 50 Hz European Std. 2-prong plug



# Scale Specifications

## Standard and Customized Scales

MicroE Systems offers a wide array of chrome on glass scales for the highest accuracy and best thermal stability. Easy to install, standard linear and rotary scales meet most application requirements. Customized linear, rotary, and rotary segment scales are available where needed. All scales include an optical index. Mercury's glass scales save time by eliminating motion system calibrations or linearity corrections required by other encoders, and provide better thermal stability than metal tape scales.

### Options include:

- *Standard linear*: 18mm - 2m
- *Standard rotary*: 12mm - 107.95mm diameter, with or without hubs
- *Custom linear\**: special lengths, widths, thickness, index mark locations and special low CTE materials
- *Custom rotary\**: special ID's, OD's (up to 304.8mm), index mark outside the main track and special low CTE materials
- *Mounting of hubs for rotary scales*: MicroE Systems can mount and align standard, custom, or customer-supplied hubs
- *Rotary segments\**: any angle range; wide range of radius values

\*Custom scales or rotary segments are available in OEM quantities. Contact your local MicroE Systems sales office.

## Standard Short Linear Scales

### 130mm and Shorter

Key: inches[mm]

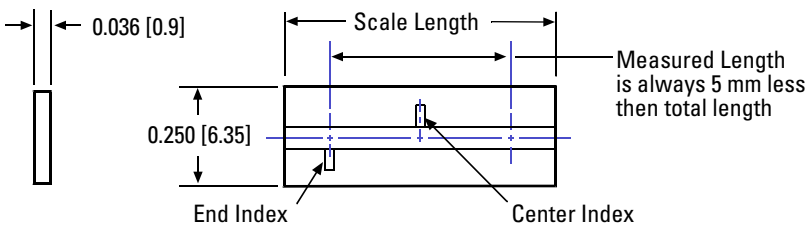

### Specifications

Accuracy	±3μm standard ±1μm available
Material	Soda lime glass
Typical CTE	8ppm/°C
Index	Center or End

Model	L18	L30	L55	L80	L105	L130
Scale Length	0.709 [18]	1.181 [30]	2.165 [55]	3.150 [80]	4.134 [105]	5.118 [130]
Measured Length	0.512 [13]	0.984 [25]	1.969 [50]	2.953 [75]	3.937 [100]	4.921 [125]

Custom scales available

## Standard Long Linear Scales

### 155mm and Longer

Key: inches[mm]

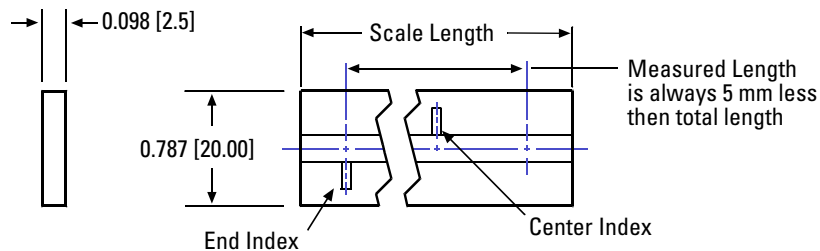

### Specifications

Accuracy	±5 μm <1m ±5 μm/m >1m
Material	Soda lime glass
Typical CTE	8ppm/°C
Index	Center or End

Model	L155	L225	L325	L425	L525	L1025	L2025
Scale length	6.102 [155]	8.858 [225]	12.795 [325]	16.732 [425]	20.669 [525]	40.354 [1025]	79.724 [2025]
Measured length	5.906 [150]	8.661 [220]	12.598 [320]	16.535 [420]	20.472 [520]	40.157 [1020]	79.528 [2020]

Custom scales available

# Standard Rotary Scales

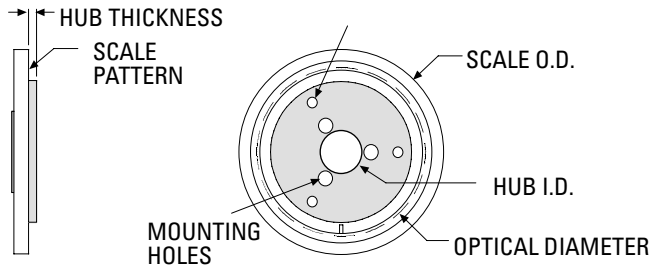

### Specifications

Material	Soda lime glass
Typical CTE	8ppm/°C

Key: inches[mm]

Model No.	Scale Outer Diameter	Scale Inner Diameter	Optical Diameter	Hub Inner Diameter +0.0005/-0.0000	Hub Thickness	Fundamental CPR
R1206	0.472 [12.00]	0.250 [6.35]	0.413 [10.50]	0.1253 [3.18]	0.040 [1.02]	1650
R1910	0.750 [19.05]	0.375 [9.52]	0.627 [15.92]	0.1253 [3.183]	0.040 [1.02]	2500
R3213	1.250 [31.75]	0.500 [12.70]	1.027 [26.08]	0.2503 [6.358]	0.050 [1.27]	4096
R5725	2.250 [57.15]	1.000 [25.40]	2.053 [52.15]	0.5003 [12.708]	0.060 [1.52]	8192
R10851	4.250 [107.95]	2.000 [50.80]	4.106 [104.30]	1.0003 [25.408]	0.080 [2.03]	16384

Custom scales available

# How to Order Mercury 3500Si Encoder Systems

To specify your Mercury encoder with the cable length, Index mode, desired scale and software, consult the chart below to create the correct part numbers for your order. Call MicroE Systems' Rapid Customer Response team for more information [508] 903-5000.

Example (Linear Encoder): M3500Si-M10-4096-2-L55-C1

Example (Rotary Encoder): M3500Si-M10-4096-3-R1910-HA

<u>M3500Si</u>	-	<u>Cable Length</u>	-	<u>Interpolation</u>	-	<u>Index Mode***</u>	-	<u>Scale Model</u>	-	<u>Scale Mounting</u>
		M05 = 0.5 m		4096		0 = No Index		Lxxx or Rxxxx		For linear scales:
		M10 = 1.0 m				1 = Zero first time				T = Tape mounting
		M20 = 2.0 m				2 = Zero every time				C1 = 3 scale clamps*
						3 = Zero first time - subtract				C2 = 10 scale clamps**
						4 = Zero every time - subtract				

\*\*\* See page 6 for details

Hubs for Rotary Scales:

- NH = Without Hub
- HE = for R1206
- HA = for R1910
- HB = for R3213
- HC = for R5725
- HD = for R10851

\* 3 clamps for linear scales up to 130mm

\*\* 10 clamps for linear scales 155mm or longer

## How to Order SmartPrecision Software

SmartPrecision Software  
 |  
 SSWA120 for 120 VAC, 60Hz  
 US Standard 2-prong plug  
 or  
 SSWA220 for 220 VAC,  
 50 Hz European Std. 2-prong plug

All Specifications are subject to change. All data is accurate to the best of our knowledge. MicroE Systems is not responsible for errors.

