



SERVOSTAR[®] 601...620

Digital Servo Amplifier

Instructions Manual

Edition 12/2010

Translation of the original manual.

Valid for Hardware Revision 05.20



Keep all manuals as a product component during the life span of the product. Pass all manuals to future users / owners of the product.

File sr601_e.***

KOLLMORGEN

Previous versions :

Edition	Remarks
05/1998	First edition
08/1998	a few corrections
09/1998	various minor corrections, parameter description removed, parameter setting for multi-axis systems and on/off switching behavior added, Installation/setup divided into two chapters
01/1999	614 added, various minor corrections
02/1999	Interface relay for digital outputs (pages 26, 43)
06/1999	various corrections, cables and connectors removed, choke box added
08/1999	24V tolerance, encoder wiring, ventilation
11/1999	Packaging, brake resistor
12/1999	Option -AS- integrated, ground-bolt, master-slave
04/2000	various corrections, setup software on CDROM only, motors 6SM27LL and 6SM37VL added
06/2000	Wiring diagrams electr. gearing, warning and error messages, recommended torque
08/2000	Wiring diagram in chapter III.9.2 corrected
07/2001	S610-30 and options -I/O-14/08- and -2CAN - incorporated, PROFIBUS and SERCOS, nameplate, motor list and connector assignment corrected, LED-display corrected, error messages expanded
02/2002	Dimensions BAR corrected
06/2002	Frontpage new design, corrections to US English, motor table removed, order numbers added, last page new design and contents, new; connection to diff. mains supply networks, block diagram to ch.III
07/2003	several corrections, DeviceNet expansion card added, directives and standards page revised, cover design
09/2003	Ethernet expansion card and Single axis controller expansion card added
03/2004	new brake resistors BAR(U), several corrections
02/2006	Company name updated, expansion cards updated, new sections on EtherCAT and SynqNet, chapter I re-structured, new sections on motor chokes, Encoder power supply and encoder termination, various error corrections, new ordering codes, Feedback section revised, BAR removed, cross section (awg)
09/2006	Hardware Revision, disposal acc. to WEEE-2002/96/EG, new structure+cover pages, Quickstart integrated
04/2007	Part number scheme, servo system graphics expanded, shock-hazard protection new, BiSS feedback, feedback expanded, enc. emulation, switch-on/off behavior and AS updated, accessories removed, DC-Bus link expanded, fuses brake resistor
07/2007	Timing diagram motor brake, motor connector, example cat.3 to EN954-1
06/2008	Repair, deinstallation, syntax: "regen" => "brake", EMC standards, Hiperface, CE declaration
08/2008	SCCR->42kA
07/2010	Logo, Repair-Disposal, ANSI Z535 safety symbols, GOST-R, HWR 5.20, holding brake hints, WIKI links
12/2010	Company name and address, CE certificate, name plate, fax form, UL markings updated

Hardware Revision (HWR)

Hardware Rev.	Firmware Rev.	DRIVE.EXE Rev.	Remarks
05.10	>= 5.76	<= 5.53_284	Firmware >=6.68 required with BiSS
05.20	>=5.81	>= 5.53_285	CAN Controller neu, Standard
	>= 6.86	>= 5.53_285	CAN Controller neu, BiSS/EtherCAT Support

WINDOWS is a registered trademark of Microsoft Corp.

HIPERFACE is a registered trademark of Max Stegmann GmbH

EnDat is a registered trademark of Dr. Johannes Heidenhain GmbH

EtherCAT is a registered trademark of EtherCAT Technology Group

SERVOSTAR is a registered trademark of Danaher Motion

Technical changes which improve the performance of the equipment may be made without prior notice !

Printed in the Federal Republic of Germany

All rights reserved. No part of this work may be reproduced in any form (by photocopying, microfilm or any other method) or stored, processed, copied or distributed by electronic means without the written permission of Kollmorgen Europe GmbH.

	Page
1 General	
1.1 About this manual	7
1.2 Target group	7
1.3 Hints for the online edition (PDF format)	7
1.4 Symbols used	8
1.5 Standards used	8
1.6 Abbreviations used	9
2 Safety	
2.1 Safety Instructions	11
2.2 Use as directed	12
2.3 Prohibited use	12
3 Approvals	
3.1 Conformance with UL and cUL	13
3.2 EC conformance	13
3.2.1 EC Declaration of Conformity	14
3.2.2 European Directives and Standards for the machine builder	15
3.3 GOST-R Conformance	16
4 Handling	
4.1 Transport	17
4.2 Packaging	17
4.3 Storage	17
4.4 Maintenance	17
4.5 Disassembling	18
4.6 Repair	18
4.7 Disposal	18
5 Package	
5.1 Package supplied	19
5.2 Nameplate	19
5.3 Part number scheme	20
6 Technical description	
6.1 The SERVOSTAR 600 family of digital servo amplifiers	21
6.2 Technical data	23
6.2.1 Recommended torque	24
6.2.2 Fusing	24
6.2.3 Ambient conditions, ventilation, mounting position	24
6.2.4 Conductor cross-sections	25
6.3 LED display	25
6.4 Control for motor holding brake	26
6.5 Grounding system	27
6.6 Electrical Brake circuit	27
6.7 Switch-on and switch-off behavior	29
6.7.1 Behavior in standard operation	30
6.7.2 Behavior in the event of an error (with standard setting)	31
6.8 Stop/Emergency Stop Function to EN 60204	32
6.8.1 Stop: Standards	32
6.8.2 Emergency Stop: Standards	33
6.9 Shock-hazard protection	34
6.9.1 Leakage current	34
6.9.2 Residual-current circuit breakers (FI)	34
6.9.3 Isolating transformers	34
7 Mechanical Installation	
7.1 Safety Instructions	35
7.2 Guide to mechanical installation	35
7.3 Assembly	36
7.4 Dimensions	37

8	Electrical Installation	
8.1	Safety Instructions	39
8.2	Guide to electrical installation	40
8.3	Wiring	41
8.3.1	Safety Instructions	41
8.3.2	Technical data for connecting cables	42
8.3.3	Shielding connection to the front panel	42
8.3.4	Motor connector with shieldplate	43
8.4	Components of a servo system	44
8.5	Block diagram	45
8.6	Pin assignments	46
8.7	Connection diagram (overview)	47
8.8	Power supply	48
8.8.1	Connection to various mains supply networks	48
8.8.2	Mains supply connection (X0)	49
8.8.3	24V auxiliary supply (X4)	49
8.8.4	DC bus link (X7)	49
8.9	Motor connection with holding brake (X9)	50
8.10	External brake resistor (X8)	50
8.11	Feedback	51
8.11.1	Resolver (X2)	52
8.11.2	Sine Encoder 5V with BiSS (X1)	53
8.11.3	Sine Encoder with EnDat 2.1 or HIPERFACE (X1)	54
8.11.4	Sine Encoder without data channel (X1)	55
8.11.5	Incremental encoder / sine encoder with Hall (X1)	56
8.11.6	Incremental Encoder (X5)	57
8.12	Electronic Gearing, Master-slave operation	58
8.12.1	Connection to a SERVOSTAR master, 5 V signal level (X5)	59
8.12.2	Connection to encoders with 24 V signal level (X3)	59
8.12.3	Connection to a sine-cosine encoder (X1)	60
8.12.4	Connection to an SSI encoder (X5)	61
8.12.5	Connection to stepper motor controllers (step and direction)	61
8.12.5.1	Step/Direction with 5 V signal level (X5)	62
8.12.5.2	Step/Direction with 24 V signal level (X3)	62
8.13	Encoder emulations	63
8.13.1	Incremental encoder output - A quad B (X5)	63
8.13.2	SSI output (X5)	64
8.14	Digital and analog inputs and outputs	65
8.14.1	Analog inputs (X3)	65
8.14.2	Analog outputs (X3)	66
8.14.3	Digital inputs (X3)	67
8.14.4	Digital outputs (X3)	68
8.15	RS232 interface, PC connection (X6)	69
8.16	CANopen Interface (X6)	70

9	Setup	
9.1	Safety Instructions	71
9.2	Setup software	72
9.2.1	General	72
9.2.1.1	Use as directed	72
9.2.1.2	Software description	72
9.2.1.3	Hardware requirements	73
9.2.1.4	Operating systems	73
9.2.2	Installation under WINDOWS	73
9.3	Quickstart Guide	74
9.3.1	Preparation	74
9.3.1.1	Unpacking, Mounting and Wiring the Servo Amplifier	74
9.3.1.2	Documents	74
9.3.1.3	Minimum Wiring for Drive Test	75
9.3.2	Connect	76
9.3.3	Important Screen Elements	77
9.3.4	Basic Setup	78
9.3.5	Motor (synchronous)	79
9.3.6	Feedback	80
9.3.7	Save Parameters and Restart	81
9.3.8	Jogging the Motor (Speed Control)	82
9.3.9	Status	83
9.3.10	Monitor	83
9.3.11	Additional Setup Parameters	83
9.4	Multi-axis systems	84
9.4.1	Node address for CAN-bus	84
9.4.2	Baud rate for CAN-bus	84
9.4.3	Example of connections for multi-axis system	85
9.5	Key operation / LED display	86
9.5.1	Key operation	86
9.5.2	Status display	86
9.5.3	Standard menu structure	87
9.5.4	Extended menu structure	87
9.6	Error messages	88
9.7	Warning messages	89
9.8	Removing faults/warnings	90
10	Expansions / Accessories	
10.1	Option -AS-, restart lock for personal safety	91
10.1.1	Safety instructions	91
10.1.2	Use as directed	92
10.1.3	Block diagram	92
10.1.4	Functional description	93
10.1.5	Signal diagram (sequence)	93
10.1.6	Functional test	94
10.1.7	Connection diagram (principle)	94
10.1.8	Application example category 1 according to EN954-1	95
10.1.8.1	Control circuit	95
10.1.8.2	Mains supply circuit	95
10.1.9	Application example category 3 according to EN954-1	96
10.1.9.1	Control circuit	96
10.1.9.2	Mains supply circuit	96
10.1.9.3	Flow chart	97
10.2	Expansion Cards	98
10.2.1	Guide to installation of expansion cards	98
10.2.2	Expansion card -I/O-14/08-	99
10.2.2.1	Front view	99
10.2.2.2	Technical data	99
10.2.2.3	Light emitting diodes (LEDs)	99
10.2.2.4	Select motion task number (Sample)	99
10.2.2.5	Connector assignments	100
10.2.2.6	Connection diagram	101

10.2.3	Expansion cards -PROFIBUS-	102
10.2.3.1	Front view	102
10.2.3.2	Connection technology	102
10.2.3.3	Connection diagram	102
10.2.4	Expansion card -SERCOS-	103
10.2.4.1	Front view	103
10.2.4.2	Light emitting diodes (LEDs)	103
10.2.4.3	Connection technology	103
10.2.4.4	Connection diagram	104
10.2.4.5	Modifying the station address	104
10.2.4.6	Modifying the baud rate and optical power	104
10.2.5	Expansion card -DEVICENET-	105
10.2.5.1	Front view	105
10.2.5.2	Connection technology	105
10.2.5.3	Connection diagram	105
10.2.5.4	Combined module/network status-LED	106
10.2.5.5	Setting the station address (device address)	106
10.2.5.6	Setting the transmission speed	106
10.2.5.7	Bus cable	107
10.2.6	Expansion card -EtherCAT-	108
10.2.6.1	Front view	108
10.2.6.2	LEDs	108
10.2.6.3	Connection diagram	108
10.2.7	Expansion card -SYNQNET-	109
10.2.7.1	Front view	109
10.2.7.2	NODE ID Switch	109
10.2.7.3	Node LED table	109
10.2.7.4	SynqNet Connection, Connector X21B/C (RJ-45)	109
10.2.7.5	Digital inputs/outputs, connector X21A (SubD 15-pin, socket)	110
10.2.7.6	Connection diagram digital inputs/outputs, connector X21A	110
10.2.8	Expansion module -2CAN-	111
10.2.8.1	Installation	111
10.2.8.2	Front View	111
10.2.8.3	Connection technology	111
10.2.8.4	Connector assignments	112
10.2.8.5	Connection diagram	112
10.3	Special Accessories	113
10.3.1	Power Supply SINCOS	113
10.3.2	Terminating adapter for encoder cables	113
10.3.3	Hall Dongle	114
11	Appendix	
11.1	Glossary	115
11.2	Order numbers	117
11.2.1	Servo amplifiers	117
11.2.2	Expansion cards	117
11.2.3	Connectors	117
11.2.4	Special accessories	117
11.3	Repair-/Disposal request Telefax form	118
11.4	Index	119

1 General

1.1 About this manual

This manual describes the digital servo amplifiers of the SERVOSTAR® 600 series (standard version, 1.5 to 20 Amps nominal current). Servoamplifiers of the SERVOSTAR 640/670 series are described in additional manuals.

NOTE

SERVOSTAR 601 is sold in Europe only.

A more detailed description of the expansion cards which are currently available and the digital connection to automation systems can be found on the accompanying CD-ROM in Acrobat-Reader format (system requirements: WINDOWS with Internet browser, Acrobat Reader) in several language versions. Technical data and dimensional drawings of accessories such as cables, brake resistors, mains supplies, etc., can be found in the accessories manual.

You can print this documentation on any standard printer. A printed copy of the documentation is available from us at extra cost.

More background information can be found in the "Product WIKI", please check www.wiki-kollmorgen.eu.

1.2 Target group

This manual addresses personnel with the following qualifications:

Transport : only by personnel with knowledge of handling electrostatically sensitive components.

Unpacking: only by electrically qualified personnel.

Installation : only by electrically qualified personnel.

Setup : only by qualified personnel with extensive knowledge of electrical engineering and drive technology

The qualified personnel must know and observe the following standards:

IEC 60364 and IEC 60664

national accident prevention regulations

⚠ WARNING

During operation there are deadly hazards, with the possibility of death, severe injury or material damage. The operator must ensure that the safety instructions in this manual are followed. The operator must ensure that all personnel responsible for working with the servo amplifier have read and understood the instructions manual.

1.3 Hints for the online edition (PDF format)

Bookmark:

Table of contents and index are active bookmarks.





Table of contents and index in the text:

The lines are active cross references. Click on the desired line and the appropriate page is indicated.

Page/chapter numbers in the text:

Page/chapter numbers with cross references are active. Click at the page/chapter number to reach the indicated target.

1.4 Symbols used

Symbol	Indication
	Indicates a hazardous situation which, if not avoided, will result in death or serious injury.
	Indicates a hazardous situation which, if not avoided, could result in death or serious injury.
	Indicates a hazardous situation which, if not avoided, could result in minor or moderate injury.
	Indicates situations which, if not avoided, could result in property damage.
	This is not a safety symbol. This symbol indicates important notes.

1.5 Standards used

Standard	Content
ISO 4762	Hexagon socket head cap screws
ISO 11898	Road vehicles — Controller area network (CAN)
ISO 13849	Safety of machinery: Safety-related parts of control systems (former EN 954)
ISO 12100	Safety of machinery: Basic concepts, general principles for design
IEC 60085	Electrical insulation - Thermal evaluation and designation Maintenance
IEC 60204	Safety of Machinery: Electrical equipment of machinery
IEC 60364	Low-voltage electrical installations
IEC 60439	Low-Voltage Switchgear and Controlgear Assemblies
IEC 60664	Insulation coordination for equipment within low-voltage systems
IEC 60721	Classification of environmental conditions
IEC 61000	Electromagnetic compatibility (EMC)
IEC 61131	Programmable controllers
IEC 61491	Electrical equipment of industrial machines – Serial data link for real-time communications between controls and drives.
IEC 61508	Functional safety of electrical/electronic/programmable electronic safety-related systems
IEC 61800	Adjustable speed electrical power drive systems
IEC 62061	Functional safety of electrical/electronic/programmable electronic safety-related systems
IEC 62079	Preparation of instructions - Structuring, content and presentation
ANSI Z535	Product safety (symbols, colors, information)
UL 840	UL Standard for Safety for Insulation Coordination Including Clearances and Creepage Distances for Electrical Equipment
UL 508C	UL Standard for Safety Power Conversion Equipment

ANSI American National Standard Institute, Inc.

IEC International Electrotechnical Commission

ISO International Organization for Standardization

UL Underwriters Laboratories

1.6 Abbreviations used

The abbreviations used in this manual are explained in the table below.

Abbrev.	Meaning
AGND	Analog ground
AS	Restart Lock, option
BTB/RTO	Ready to operate
CAN	Fieldbus (CANopen)
CE	Communauté Européenne (EC)
CLK	Clock signal
COM	Serial interface for a PC-AT
DGND	Digital ground
DIN	German Institute for industrial Standards
Disk	Magnetic storage (diskette, hard disk)
EEPROM	Electrically erasable programmable memory
EMC	Electromagnetic compatibility
EMI	Electromagnetic interference
EN	European standard
ESD	Electrostatic discharge
F-SMA	Fiber Optic Cable connector according to IEC 60874-2
IEC	International Electrotechnical Commission
INC	Incremental Interface
ISO	International Standardization Organization
LED	Light-emitting diode
MB	Megabyte
NI	Zero pulse
NSTOP	Limit-switch input for CCW rotation (left)
PELV	Protected low voltage
PGND	Ground for the interface
PSTOP	Limit-switch input for CW rotation (right)
RAM	Volatile memory
R _B	Brake (regen) resistor
R _{Bext}	External brake resistor
R _{Bint}	Internal brake resistor
RES	Resolver
ROD 426 (EEO)	A quad B encoder
PLC	Programmable logic controller
SRAM	Static RAM
SSI	Synchronous serial interface
UL	Underwriters Laboratory
VAC	AC voltage
VDC	DC voltage
VDE	Verein deutscher Elektrotechniker
XGND	Ground for the 24V supply

This page has been deliberately left blank.

2 Safety

2.1 Safety Instructions

⚠ DANGER During operation there are deadly hazards, with the possibility of death, severe injury or material damage. Do not open or touch the equipment during operation. Keep all covers and cabinet doors closed during operation. Touching the equipment is allowed during installation and commissioning for properly qualified persons only.

- During operation, servo amplifiers may have uncovered live components, depending on their level of enclosure protection.
- Control and power connections may be live, even though the motor is not rotating.
- Servo amplifiers may have hot surfaces during operation. Surface can reach temperatures above 80°C.

⚠ WARNING There is a danger of electrical arcing with damage to contacts and personal injury. Never undo any electrical connections to the servo amplifier while it is live. Wait at least five minutes after disconnecting the servo amplifier from the main supply power before touching potentially live sections of the equipment (e.g. contacts) or undoing any connections. Capacitors can still have dangerous voltages present up to five minutes after switching off the supply power. To be sure, measure the voltage in the DC Bus link and wait until it has fallen below 40V.

⚠ CAUTION Incorrect handling of the servo amplifier can lead to personal injury or material damage. Read this documentation before carrying out the installation and commissioning. It is vital that you keep to the technical data and information on connection requirements (nameplate and documentation). Only properly qualified personnel are permitted to carry out activities such as transport, installation, commissioning and maintenance. Properly qualified persons are those who are familiar with the transport, assembly, installation, commissioning and operation of the product, and who have the appropriate qualifications for their job. The qualified personnel must know and observe the following standards:

- IEC 60364 and IEC 60664
- national accident prevention regulations

⚠ CAUTION The manufacturer of the machine must produce a hazard analysis for the machine and take appropriate measures to ensure that unforeseen movements do not result in personal injury or material damage.

NOTICE Check the Hardware Revision Number of the product (see product label). This revision number must match the Hardware Revision Number on the cover page of the manual.

NOTICE The servo amplifiers contain electrostatically sensitive components which may be damaged by incorrect handling. Discharge your body before touching the servo amplifier. Avoid contact with highly insulating materials (artificial fabrics, plastic film etc.). Place the servo amplifier on a conductive surface.

2.2

Use as directed

- The servo amplifiers are components which are built into electrical equipment or machines, and can only be used as integral components of such equipment.
- The manufacturer of the machine must generate a hazard analysis for the machine, and take appropriate measures to ensure that unforeseen movements cannot cause injury or damage to any person or property.
- The SERVOSTAR 600 family of servo amplifiers (overvoltage category III acc. to EN 61800-5-1) can be connected directly to symmetrically earthed (grounded) three-phase industrial mains supply networks [TN-system, TT-system with earthed (grounded) neutral point, not more than 42,000 rms symmetrical amperes, 480VAC maximum].
Connection to different mains supply networks (with additional isolating transformer) ⇒ p.48.
- Periodic overvoltages between outer conductor (L1, L2, L3) and housing of the servo amplifier may not exceed 1000V (peak value).
Transient overvoltages (< 50µs) between the outer conductors may not exceed 1000V.
Transient overvoltages (< 50µs) between outer conductors and housing may not exceed 2000V.
- If the servo amplifiers are used in residential areas, or in business or commercial premises, then additional filter measures must be implemented by the user.
- The SERVOSTAR 600 family of servo amplifiers is **only** intended to drive specific brushless synchronous servomotors, with closed-loop control of torque, speed and/or position. The rated voltage of the motors must be at least as high as the DC bus link voltage of the servo amplifier.
- The servo amplifiers **may only** be operated in a closed switchgear cabinet, taking into account the ambient conditions defined on page 24 and the dimensions shown on page 36. Ventilation or cooling may be necessary to prevent enclosure ambient from exceeding 45°C (113°F).
- Use only copper wire. Wire size may be determined from EN 60204 (or table 310-16 of the NEC 60°C or 75°C column for AWG size).
- Consider the specifications on page 92 when you use the optional personnel safe restart lock -AS-.

2.3

Prohibited use

- Other use than described in chapter 2.2 is not intended and can lead to damage of persons, equipment or things.
- The use of the servo amplifier in the following environments is prohibited:
 - potentially explosive areas
 - environments with corrosive and/or electrically conductive acids, alkaline solutions, oils, vapours, dusts
 - directly on non-grounded supply networks or on asymmetrically grounded supplies with a voltage >240V.
 - on ships or off-shore applications
- Commissioning the servo amplifier is prohibited if the machine in which it was installed,
 - does not meet the requirements of the EC Machinery Directive
 - does not comply with the EMC Directive or with the Low Voltage Directive
 - does not comply with any national directives
- The control of holding brakes by the SERVOSTAR 600 alone may not be used in applications, where personnel security is to be ensured with the brake.

3 Approvals

3.1 Conformance with UL and cUL

This servo amplifier is listed under UL file number **E217428**.

UL (cUL)-certified servo amplifiers (Underwriters Laboratories Inc.) fulfil the relevant U.S. and Canadian standard (in this case UL 840 and UL 508C).

This standard describes the fulfilment by design of minimum requirements for electrically operated power conversion equipment, such as frequency converters and servo amplifiers, which is intended to eliminate the risk of fire, electric shock, or injury to persons, being caused by such equipment.

The technical conformance with the U.S. and Canadian standard is determined by an independent UL (cUL) inspector through the type testing and regular check-ups.

Apart from the notes on installation and safety in the documentation, the customer does not have to observe any other points in direct connection with the UL (cUL)-certification of the equipment.

UL 508C

UL 508C describes the fulfilment by design of minimum requirements for electrically operated power conversion equipment, such as frequency converters and servo amplifiers, which is intended to eliminate the risk of fire being caused by such equipment.

UL 840

UL 840 describes the fulfilment by design of air and insulation creepage spacings for electrical equipment and printed circuit boards.

3.2 EC conformance

Conformance with the EC EMC Directive 2004/108/EC and the Low Voltage Directive 2006/95/EC is mandatory for the supply of servo amplifiers within the European Community. Product standard EN 61800-3 is applied to ensure conformance with the EMC Directive

Concerning noise immunity the servo amplifier meets the requirements to the 2nd environmental category (industrial environment). For noise emission the amplifier meets the requirement to a product of the category C3.

NOTICE

This product can cause high-frequency interferences in non industrial environments which can require measures for interference suppression.

The servo amplifiers have been tested in a defined configuration, using the system components that are described in this documentation. Any divergence from the configuration and installation described in this documentation means that you will be responsible for carrying out new measurements to ensure conformance with regulatory requirements. The standard IEC 61800-5-1 is applied to ensure conformance with the Low Voltage Directive.

3.2.1

EC Declaration of Conformity

EC Declaration of Conformity		KOLLMORGEN [™]
Document No.: GL-11/20/48/10		
We, the company		
Kollmorgen Europe GmbH Pempelfurtstraße 1 D-40880 Ratingen		
hereby in sole responsibility declare the conformity of the product series		
Servo drive SERVOSTAR 600 (S600)		
with the following standards:		
- EC Directive 2004/108/EC Electromagnetic compatibility Used harmonized standard EN61800-3 (07/2005)		
- EC Directive 2006/95/EC Electrical devices for use in special voltage limits Used harmonized standard EN61800-5-1 (04/2008)		
Year of EC-Declaration	1999	
Issued by:	Product Manager Drives Europe Holger Goergen Ratingen, 01.12.2010	
Legally valid signature		
The above-mentioned company has the following technical documentation for examination:		
- Proper operating instructions		
- Setup Software		
- Diagrams / software source codes (for EU authority only)		
- Test certificates (for EU authority only)		
- Other technical documentation (for EU authority only)		
The special technical product documentation has been created.		
Responsible person for documentation: Lars Lindner, Phone: +49(0)2102/9394-0		

3.2.2 European Directives and Standards for the machine builder

Servo amplifiers are components that are intended to be incorporated into electrical plant and machines for industrial use. When the servo amplifiers are built into machines or plant, the amplifier must not be used until it has been established that the machine or equipment fulfills the requirements of the

- EC Machinery Directive (2006/42/EC)
- EC EMC Directive (2004/108/EC)
- EC Low Voltage Directive (2006/95/EC)

Standards to be applied for conformance with the EC Machinery Directive (2006/42/EC)

EN 60204-1 (Safety and Electrical Equipment in Machines)
EN 12100 (Safety of Machines)



**The manufacturer of the machine must generate a hazard analysis for the machine, and must implement appropriate measures to ensure that unforeseen movements cannot cause injury or damage to any person or property.
The machine/plant manufacturer must check whether other standards or EC Directives must be applied to the machine/plant.**

Standards to be applied for conformance with the EC Low Voltage Directive(2006/95/EC)

EN 60204-1 (Safety and Electrical Equipment in Machines)
EN 60439-1 (Low Voltage Switchgear Combinations)

Standards to be applied for conformance with the EC EMC Directive (2004/108/EC)

EN 61000-6-1 / 2 (Interference Immunity in Residential & Industrial Areas)
EN 61000-6-3 / 4 (Interference Generation in Residential & Industrial Areas)

The manufacturer of the machine/plant is responsible for ensuring that it meets the limits required by the EMC regulations. Advice on the correct installation for EMC (such as shielding, grounding, treatment of connectors and cable layout) can be found in this documentation.

We only guarantee the conformance of the servo system with the standards cited in this chapter if the components (motor, cables, chokes etc.) are those supplied by us.

3.3 GOST-R Conformance

Certificate for servo amplifiers and accessories (cover page).

СИСТЕМА СЕРТИФИКАЦИИ ГОСТ Р ГОССТАНДАРТ РОССИИ	
	СЕРТИФИКАТ СООТВЕТСТВИЯ
№ РОСС DE.АЯ46.Н46049	
Срок действия с 11.05.2009 по 10.05.2012	
0885845	
ОРГАН ПО СЕРТИФИКАЦИИ	
ПРОМЫШЛЕННОЙ ПРОДУКЦИИ РОСТЕСТ- МОСКВА РОСС RU.0001.11АЯ46	
117418 Москва, Нахимовский проспект, 31 тел.(495) 129-26-00; (371) 6721-28-93	
ПРОДУКЦИЯ	
преобразователи частоты (сервоусилители) серий Servostar xxx-yy и S7xxxx с комплектующими согласно приложению к сертификату на двух листах, бланки № 2154074 - № 2154075, серийный выпуск	код ОК 005 (ОКП): 340000
СООТВЕТСТВУЕТ ТРЕБОВАНИЯМ НОРМАТИВНЫХ ДОКУМЕНТОВ	
ГОСТ 12.2.007.0-75, ГОСТ 12.2.007.11-75, ГОСТ 26830-86	код ТН ВЭД: 8504
ИЗГОТОВИТЕЛЬ	
"Danaher Motion GmbH", Wacholderstr. 40-42, 40489 Duesseldorf, Германия	
СЕРТИФИКАТ ВЫДАН	
"Danaher Motion GmbH", Wacholderstr. 40-42, 40489 Duesseldorf, Германия	
НА ОСНОВАНИИ	
протокола испытаний компании DANAHER № 3613 от 16.04.2009г.	
ДОПОЛНИТЕЛЬНАЯ ИНФОРМАЦИЯ	
Схема сертификации 3. Продукция маркируется знаком соответствия. Форма и размеры знака по ГОСТ Р 50460-92. Сертификат без приложений не действителен.	
	Руководитель органа Эксперт
	А.Б.Савкин инициалы, фамилия
	Б.П.Чумаков инициалы, фамилия
Сертификат не применяется при обязательной сертификации	
<small>Бланк изготовлен ЗАО "ОПТИС" (лицензия № 05-05-003 МР РФ уполном. в) тел. (495) 648 6068, 208 7617, г. Москва, 2007 г.</small>	

4 Handling

4.1 Transport

- Only by qualified personnel in the manufacturer's original recyclable packaging
- Avoid shocks
- Temperature -25 to +70°C, max. 20K/hr rate of change
- Humidity max. 95% relative humidity, no condensation

NOTICE

- **The servo amplifiers contain electrostatically sensitive components which can be damaged by incorrect handling. Discharge yourself before touching the servo amplifier. Avoid contact with highly insulating materials (artificial fabrics, plastic films etc.). Place the servo amplifier on a conductive surface.**
- If the packaging is damaged, check the unit for visible damage. In this case, inform the shipper and the manufacturer.

4.2 Packaging

- Cardboard box, can be recycled
- Dimensions: SERVOSTAR 601...610 (HxWxD) 125x415x350 mm
 SERVOSTAR 614 / 620 (HxWxD) 170x415x350 mm
- Labeling : nameplate outside at the box

4.3 Storage

- Storage only in the manufacturer's original recyclable packaging
- Max. stacking height 8 cartons
- Storage temperature -25 to +55°C, max. rate of change 20°C / hour
- Storage humidity 5 ... 95% relative humidity, no condensation
- Storage duration Less than 1 year without restriction.
More than 1 year: capacitors must be **re-formed** before setting up and operating the servo amplifier. To do this, remove all electrical connections and apply single-phase 230V AC for about 30 minutes to the terminals L1 / L2.

4.4 Maintenance

The instruments do not require any maintenance, opening the instruments invalidates the warranty.

Cleaning : — if the casing is dirty: clean with Isopropanol or similar

Note: do not immerse or spray

— if there is dirt inside the unit it must be cleaned by the manufacturer

— dirty protective grill on fan must be cleaned with a dry brush

4.5 Disassembling

Observe the sequence below, if a servo amplifier has to be disassembled (e.g. for replacement).

1. Electrical disconnection

**WARNING**

Switch off the main switch of the switchgear cabinet and the fuses that supply the system. Wait at least eight minutes after disconnecting the servo amplifier from the main supply power before touching potentially live sections of the equipment (e.g. contacts) or undoing any connections. To be sure, measure the voltage in the DC Bus link and wait until it has fallen below 40V.

Remove the connectors. Disconnect the earth (ground) connection at last.

2. Check temperature

**CAUTION**

During operation the heat sink of the servo amplifier may reach temperatures above 80°C (176°F). Before touching the device, check the temperature and wait until it has cooled down below 40°C (104°F).

3. Disassembling

Remove the fan housing and disassemble the servo amplifier (reverse of the procedure described in chapter "Mechanical installation).

4.6 Repair

Repair of the servo amplifier must be done by the manufacturer. Opening the devices means loss of the guarantee. Use the telefax form on page 118 for repair request. You'll receive the current dispatch information.

Disassemble the equipment as described in chapter 4.5 and send it in the original packaging to the address given in the dispatch information.

4.7 Disposal

In accordance to the WEEE-2002/96/EC-Guidelines we take old devices and accessories back for professional disposal. Transport costs are the responsibility of the sender. Use the telefax form on page 118 for disposal request. You'll receive the current dispatch information.

Disassemble the equipment as described in chapter 4.5 and send it in the original packaging to the address given in the dispatch information.

5 Package

5.1 Package supplied

When you order a SERVOSTAR 600 series amplifier (order numbers ⇒ p.117), you will receive:

- SERVOSTAR 6xx
- mating connectors X3, X4, X0A, X0B, X7, X8

NOTE The mating SubD connectors and motor connector X9 are not part of the package!

- Assembly, Installation and Setup Instructions (Instructions Manual)
- Online documentation on CD-ROM
- Setup software DRIVE.EXE on CD-ROM





Accessories: (must be ordered separately; description see accessories manual)

- AC synchronous servomotor (linear or rotary)
- motor cable (pre-assembled), or both motor connectors separately, with motor cable as a cut-off length
- feedback cable (pre-assembled or both feedback connectors separately, with feedback cable as length)
- Power supply for encoders with a power consumption of more than 150mA (⇒ p. 113)
- Terminating adapter for encoders with no terminating resistors (⇒ p. 113)
- motor choke 3YL for cable length above 25m
- external brake resistor BAR(U)
- communications cable to the PC(⇒ p.69) or Y-adapter (⇒ p.84) for setting parameters of up to 6 servo amplifiers from one PC
- power cable, control cables, fieldbus cables (as lengths)

5.2 Nameplate

The nameplate depicted below is attached to the side of the servo amplifier. The information described below is printed in the individual fields.

Servo amplifier type	Serial number	Comments	Hardware Revision
----------------------	---------------	----------	-------------------

Kollmorgen Europe GmbH Pempelfurtstraße 1 D-40880 Ratingen www.kollmorgen.com	Customer Support Europe Tel. +49 (0)2102 / 93940 Italy Tel. +39 (0)362 / 594260 North America Tel. +1 540 633 3545	 E217428  LISTED IND. CONT. EQ. 1VD4 			
Typenbezeichnung	Model Number	Ser. Nr	Ser. No.	Bemerkung	Comment
Eingang	Input	Ausgang	Nom. Current		
Spannung / Voltage: 3x230V - 480V, 50Hz Spannung / Voltage: 3x208V - 480V, 60Hz Nennstrom / Full load current: xxA		Zwischenkreisspannung/DC-Link Voltage: 260V - 675V Phasen / Phases: 3 Strom/Current: xxA Schaltfrequenz / Bases Frequency: 8kHz (16kHz with VDCmax=400V)			
Umgebungstemp. Surroundingtemp.	45°C	RoHS conform	Schutzart Encl.Rating	IP20	Hardware Revision xx.yy
 example		Made in Austria		 example	

5.3 Part number scheme

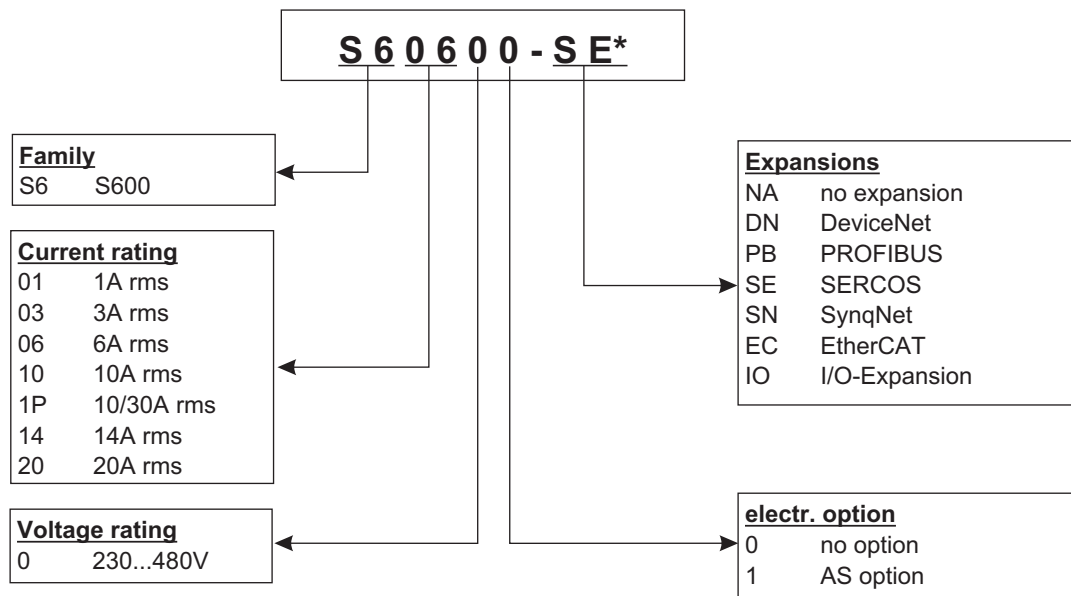

* additional coding defines customer specific specials.

Comparison (without expansion) device name -> part number

Device Name	Part Number
SERVOSTAR 601	S60100-NA
SERVOSTAR 603	S60300-NA
SERVOSTAR 606	S60600-NA
SERVOSTAR 610	S61000-NA
SERVOSTAR 610-30	S61P00-NA
SERVOSTAR 614	S61400-NA
SERVOSTAR 620	S62000-NA

6 Technical description

6.1 The SERVOSTAR 600 family of digital servo amplifiers

Standard version

- 6 current ratings (1.5 A -Europe only-, 3 A , 6 A , 10 A , 14 A, 20 A)
- 3 instrument widths :
 - 70 mm for 1.5A up to 10A rated current
 - 100 mm for 14A rated current
 - 120 mm for 20A rated current
- Wide range of rated voltage (3x208V -10% to 3x480V $+10\%$)
- Overvoltage category III acc. to EN 61800-5-1
- Shield connection directly at the servo amplifier
- 2 analog setpoint inputs
- Integrated CANopen (default 500 kBaud), for integration into CAN bus systems and for setting parameters for several amplifiers via the PC-interface of one amplifier
- Integrated RS232, electrically isolated, integrated pulse-direction interface
- Synchronous servomotors, linear motors and asynchronous motors can be used

Electrical supply

- Directly off grounded 3 phase system,
 - 230V -10% ... 480V $+10\%$, 50 Hz,
 - 208V -10% ... 480V $+10\%$, 60 HzTN-system or TT-system with grounded neutral point, max. 42,000 rms symmetrical amperes. Connection to other mains supply networks only with insulating transformer ⇒ p.48
- B6 rectifier bridge, directly off 3-phase earthed (grounded) supply system, integral power input filter and inrush circuit
- Single-phase supply (e.g. for setup) is possible
- Fusing: (e.g. fusible cutout) provided by the user
- Shielding: All shielding connections directly on the amplifier
- Output stage: IGBT- module with isolated current measurement
- Brake circuit: with dynamic distribution of the brake power between several amplifiers on the same DC bus link circuit. Internal brake resistor as standard, external brake resistors if required
- DC bus link voltage 260 — 900 VDC, can be switched in parallel
- Interference suppression filter for the supply input (to category 3) is integrated
- Interference suppression filter for the 24V aux. supply (to category 3) is integrated

Integrated safety

- Safe electrical separation between the power input / motor connections and the signal electronics, provided by appropriate insulation/creepage distances and complete electrical isolation
- Soft-start, overvoltage recognition, short-circuit protection, phase-failure monitoring
- Temperature monitoring of servo amplifier and motor (when using our motors with our pre-assembled cables)

Auxiliary supply voltage 24VDC

- Electrically isolated, internal fusing (3.15 AT), from an external 24VDC psu, e.g. with insulating transformer

Operation and parameter setting

- With our user-friendly software for setup through the serial interface of a PC
- Direct operation by means of two keys on the servo amplifier and a 3-character LED display for status display in case there is no PC available
- Fully programmable via RS232 interface

Completely digital control

- Digital current controller (space vector pulse-width modulation, 62.5 μ s)
- digital speed controller adaptable to most different load conditions (65 μ s or 250 μ s)
- Integral position controller with adaptation possibilities for customer needs (250 μ s)
- Pulse direction interface integrated for connection of a servomotor to a stepping motor control
- Evaluation of the resolver signals and sine-cosine signals of a high-resolution encoder
- Encoder simulation (incremental or SSI)

Auxiliary functions

- 2 analog monitor outputs
- 4 programmable digital inputs (normally, two are defined as limit-switch inputs)
- 2 programmable digital outputs
- Freely programmable combinations of all digital signals

Options/Expansions

- Option -AS-, built-in safety relay (personnel-safety starting lock-out) \Rightarrow p. 91
- I/O expansion card \Rightarrow p. 99
- PROFIBUS DP expansion card \Rightarrow p. 102
- SERCOS expansion card \Rightarrow p. 103
- DeviceNet expansion card \Rightarrow p. 105
- EtherCAT expansion card \Rightarrow p. 108
- SynqNet expansion card \Rightarrow p. 109
- -2CAN- expansion module, separated connectors for CAN bus and RS232 \Rightarrow p. 111
- Third party expansion cards (ModBus, FireWire, LightBus etc. - contact distributors for further information)

6.2 Technical data

		SERVOSTAR							
Rated data	DIM	601	603	606	610	610-30	614	620	
Rated supply voltage (grounded system)	V~	3 x 230V _{-10%} ... 480V _{+10%} , 50 Hz							
	V~	3 x 208V _{-10%} ... 480V _{+10%} , 60 Hz							
Rated installed load for S1 operation	kVA	1	2	4	7	7	10	14	
Rated DC bus link voltage	V=	290 - 675							
Rated output current (rms value, ± 3%)	A _{rms}	1.5	3	6	10	10	14	20	
Peak output current (max. ca. 5s, ± 3%)	A _{rms}	3	6	12	20	30 (2s)	28	40	
Clock frequency of the output stage	kHz	8 (16 with VDCmax=400V)							
Technical data for brake circuit	—	⇒ p.27							
Overvoltage protection threshold	V	450...900							
Max. load inductance	mH	150	75	40	25	24	15	12	
Min. load inductance	mH	25	12	7.5	4	4	2.5	2	
Form factor of the output current (at rated data and min. load inductance)	—	1.01							
Bandwidth of subordinate current controller	kHz	> 1.2							
Residual voltage drop at rated current	V	5							
Quiescent dissipation, output stage disabled	W	15							
Dissipation at rated current (incl. power supply losses, without brake dissipation)	W	30	40	60	90	90	160	200	
Inputs									
Setpoint 1/2, resolution 14bit/12bit	V	±10							
Common-mode voltage max.	V	±10							
Input resistance to AGND	kΩ	20							
Digital inputs	V	according to IEC 61131							
Digital outputs, open collector	V	according to IEC 61131							
BTB/RTO output, relay contacts	V	DC max. 30, AC max. 42							
	mA	500							
Aux. power supply, electrically isolated without brake	V	24 (-0% +15%)							
	A	1 (max. 16)							
Aux. power supply, electrically isolated with brake (consider voltage loss!)	V	24 (-0% +15%)							
	A	3 (max. 16)							
Min./max. output current, brake	A	0,15 / 2							
Connections									
Control signals	—	Combicon 5.08 / 18 pole , 2,5mm ²							
Power signals	—	Power Combicon 7.62 / 4x4 + 1x6-pole, 4mm ²							
Resolver input	—	SubD 9pole (socket)							
Sine-cosine encoder input	—	SubD 15pole (socket)							
PC-interface, CAN	—	SubD 9pole (plug)							
Encoder simulation, ROD (EEO) / SSI	—	SubD 9pole (plug)							
Mechanical									
Weight	kg	4					5	7.5	
Height without connectors	mm	275							
Width	mm	70					100	120	
Depth without connectors	mm	265							

6.2.4 Conductor cross-sections

Technical data for connection cables ⇒ p.42. Following EN 60204 (for AWG: table 310-16 of the NEC 60°C or 75°C column), we recommend for **single-axis systems**:

AC connection	SERVOSTAR 601-610: 1.5 mm ² (14awg) SERVOSTAR 614/620: 4 mm ² (12awg)	600V,80°C (176°F), twisted
DC bus link	SERVOSTAR 601-610: 1.5 mm ² (14awg) SERVOSTAR 614/620: 4 mm ² (12awg)	600V,80°C (176°F), shielded for lengths>20cm
Motor cables up to 25 m length*	SERVOSTAR 601-610: 1-1.5 mm ² (14awg) SERVOSTAR 614/620: 2.5 mm ² (12awg)	600V,80°C (176°F), shielded, capacitance <150pF/m
Motor cables 25 to 100 m length*, with motor choke 3YL	SERVOSTAR 601-606: 1 mm ² (14awg) SERVOSTAR 610-620: 2.5 mm ² (12awg)	600V,80°C (176°F), shielded, capacitance <150pF/m
Resolver, thermal control, max.100m length*	4x2x0.25 mm ² (22awg) twisted pairs, shielded, capacitance <120pF/m	
Encoder, thermal control, max.50m length*	7x2x0,25 mm ² (22 awg) twisted pairs, shielded, capacitance <120pF/m	
Setpoints, monitors, AGND	0.25 mm ² (22awg) twisted pairs, shielded	
Control signals, BTB, DGND	0.5 mm ² (20awg)	
Holding brake (motor)	min. 0.75 mm ² (18awg), 600V,80°C (176°F), shielded, check voltage drop	
+24 V / XGND	max. 2.5 mm ² (12awg), check voltage drop	

NOTICE

For multi-axis systems, please note the special operating conditions in your installation. To reach the max. permitted cable length, observe cable requirements ⇒ p. 42.

* Kollmorgen North America delivers cables up to 39m length.
Kollmorgen Europe delivers cables up to the maximum length.

6.3 LED display

A 3-character LED display shows the amplifier status after switching on the 24V supply (⇒ p.86). During operation of the amplifier via the keys on the front panel, the parameter and function numbers (⇒ p.87) are displayed, as well as the numbers of any errors which occur (⇒ p.88).

6.4 Control for motor holding brake

A 24V / max. 2A holding brake in the motor can be controlled directly by the servo amplifier.

CAUTION This function does not ensure personnel safety! Hanging load (vertical axes) require an additional mechanical brake which must be safely operated.

NOTE Check voltage drop, measure the voltage at brake input and check brake function (brake and no brake).

The brake function must be enabled through the BRAKE parameter (setting: WITH BRAKE). In the diagram below you can see the time and functional relationships between the ENABLE signal, speed setpoint, speed and braking force.

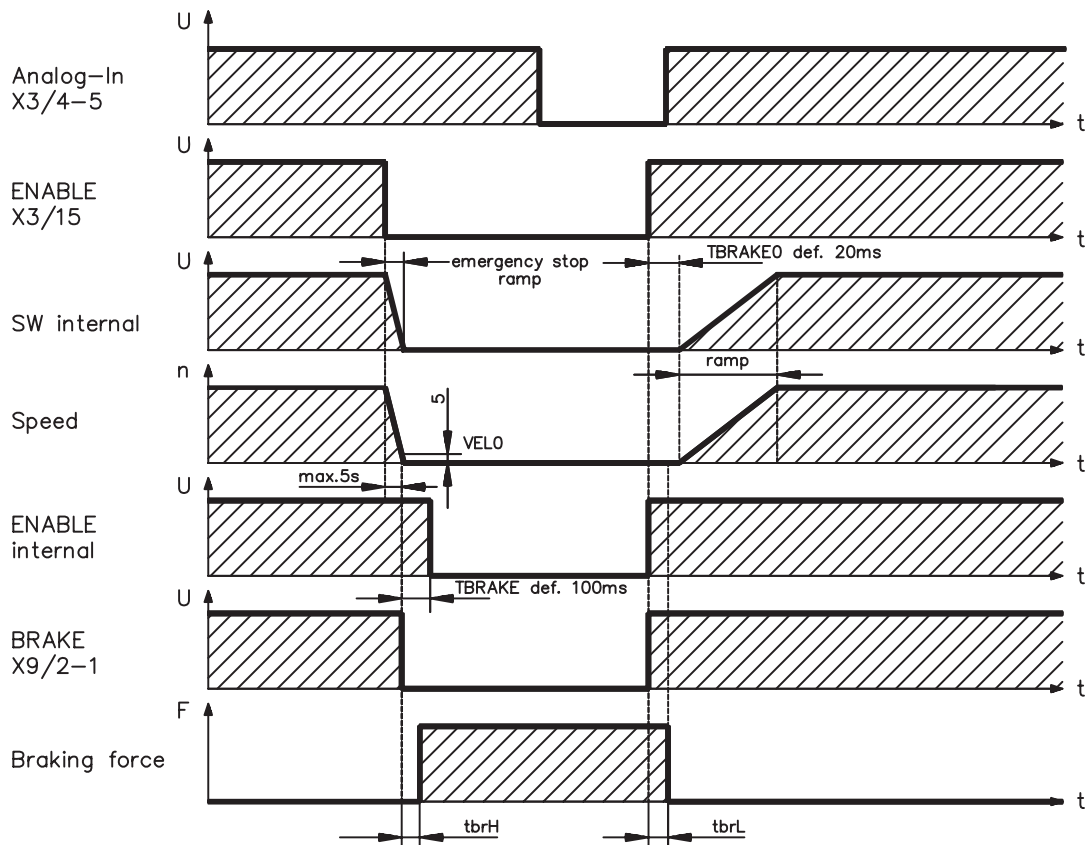

During the internal ENABLE delay time of 100ms (DECDIS) the speed setpoint of the servo amplifier is internally driven down a 10ms ramp to 0. The brake output is switched on when the speed 5rpm (VELO) is reached or after 5s (EMRGTO) the latest.

The rise (tbrH) and fall (tbrL) times of the holding brake which is built into the motors are different for the various types of motor (see motor manual).

A description of the interface can be found on page 50 .

6.5 Grounding system

AGND — ground for analog inputs/outputs, internal analog/ μ C ground
 DGND — ground for digital inputs/outputs, optically isolated
 XGND — ground for external 24V aux. voltage, optically and inductively isolated
 PGND — ground for encoder simulation, RS232, CAN, optically isolated

The potential isolation is shown in the block diagram (\Rightarrow p. 45).

6.6 Electrical Brake circuit

During electrical braking with the aid of the motor, energy is fed back to the servo amplifier. This energy is converted into heat in the brake resistor. The brake circuit (thresholds) are adjusted to the supply voltage with the help of the setup software.

Our customer service can help you with the calculation of the brake power which is required. A [simple method](#) is described in the "Product Wiki" which is accessible at www.wiki-kollmorgen.eu. A description of the interface can be found on page 50.

Internal brake resistor

SERVOSTAR 601/603	66 Ω
SERVOSTAR 606-620	33 Ω

External brake resistor

SERVOSTAR 601-620	33 Ω
-------------------	-------------

Functional description

1.- Individual amplifiers, **not coupled** through the DC bus link (DC+, DC-)

The circuit starts to respond at a DC bus link voltage of 400V, 720V or 840V (depending on the supply voltage).

If the energy which is fed back from the motor, as an average over time or as a peak value, is higher than the preset brake power, then the servo amplifier will output the status "brake power exceeded" and the brake circuit will be switched off.

At the next internal check of the DC bus link voltage (after a few ms) an overvoltage will be detected and the servo amplifier will be switched off with the error message "Overvoltage F02" (\Rightarrow p.88).

The BTB/RTO contact (terminal X3/2,3) will be opened at the same time (\Rightarrow p.68)

2.- Several servo amplifiers **coupled** through the DC bus link circuit (DC+, DC-)

Thanks to the built-in brake circuit, several amplifiers (even with different current ratings) can be operated off a common DC bus link. This is achieved by an automatic adjustment of the brake thresholds (which vary, because of tolerances). The brake energy is distributed equally among all the amplifiers.

The **combined power** of all the amplifiers is always available, as continuous or peak power. The switch-off takes place as described under 1. (above) for the servo amplifier with the lowest switch-off threshold (resulting from tolerances). The RTO (BTB) contact of this amplifier (terminals X3/2,3) will be opened at the same time (\Rightarrow p.68).

Technical Data

The technical data depend on the used servo amplifier type and on the mains voltage. See table on the next page.

Brake circuit: technical data			SERVOSTAR	
Supply voltage	Rated data	DIM	601 - 603	606 - 620
3 x 230 V	Upper switch-on level of brake circuit	V	400 - 430	
	Switch-off level of brake circuit	V	380 - 410	
	Overvoltage F02	V	450	
	Continuous power of brake circuit (R_{Bint})	W	80	200
	Continuous power of brake circuit (R_{Bext}) max.	kW	0.25	0.75
	Pulse power, internal (R_{Bint} max. 1s)	kW	2.5	5
	Pulse power, external (R_{Bext} max. 1s)	kW	5	
	External brake resistor	Ω	33	
3 x 400 V	Upper switch-on level of brake circuit	V	720 - 750	
	Switch-off level of brake circuit	V	680 - 710	
	Overvoltage F02	V	800	
	Continuous power of brake circuit (R_{Bint})	W	80	200
	Continuous power of brake circuit (R_{Bext}) max.	kW	0.4	1.2
	Pulse power, internal (R_{Bint} max. 1s)	kW	8	16
	Pulse power, external (R_{Bext} max. 1s)	kW	16	
	External brake resistor	Ω	33	
3 x 480 V	Upper switch-on level of brake circuit	V	840 - 870	
	Switch-off level of brake circuit	V	800 - 830	
	Overvoltage F02	V	900	
	Continuous power of brake circuit (R_{Bint})	W	80	200
	Continuous power of brake circuit (R_{Bext}) max.	kW	0.5	1.5
	Pulse power, internal (R_{Bint} max. 1s)	kW	10.5	21
	Pulse power, external (R_{Bext} max. 1s)	kW	21	
	External brake resistor	Ω	33	

NOTE Suitable external brake resistors can be found in our accessories manual.

6.7 Switch-on and switch-off behavior

This chapter describes the switch-on and switch-off behavior of the SERVOSTAR and the steps required to achieve operational stopping or emergency stop behavior that complies with standards.

NOTE

The servo amplifier's 24 V supply must remain constant. The ASCII commands ACTFAULT (error response) and STOPMODE (ENABLE signal response) dictate how the drive will behave.

STOPMODE	ACTFAULT	Behavior (see also ASCII reference in the online help of the setup software)
0 (default)	0	Motor coasts to a standstill in an uncontrolled manner
1	1 (default)	Motor is braked in a controlled manner

Behavior during a power failure

The servo amplifiers use an integrated circuit to detect if one or more input phases (power supply feed) fail. The behavior of the servo amplifier is set using the setup software: Under "**Response to Loss of Input Phase**" (PMODE) on the **Basic Setup** screen, select:

- **Warning** if the higher-level control system is to bring the drive to a standstill: Warning n05 is output if an input phase is missing, and the motor current is limited to 4 A. The servo amplifier is not disabled. The higher-level control system can now selectively end the current cycle or start bringing the drive to a standstill. Therefore, the error message "MAINS BTB, F16" is output on a digital output of the servo amplifier and evaluated by the control system, for instance.
- **Error message** if the servo amplifier is to bring the drive to a standstill: Error message F19 is output if an input phase is missing. The servo amplifier is disabled and the BTB contact opens. Where the factory setting is unchanged (ACTFAULT=1), the motor is braked using the set "EMERGENCY STOP RAMP".

Behavior when undervoltage threshold is reached

If the undervoltage threshold is undershot in the DC bus link (the threshold value depends on the type of servo amplifier), the error message "UNDERVOLTAGE, F05" is displayed. The drive response depends on the ACTFAULT/STOPMODE setting.

Behavior with enabled "holding brake" function

Servo amplifiers with an enabled holding brake function have a special procedure for switching off the output stage (⇒ p. 26). Removing the ENABLE signal triggers electrical braking. As with all electronic circuits, the general rule applies that there is a possibility of the internal "holding brake" module failing. Bringing a motor to a standstill using a holding brake in a way that is personnel safe also requires an electromechanical "make" contact for the holding equipment and a suppressor device for the brake.

Behavior of the optional restart lock -AS-

With the personnel safe restart lock -AS-, the drive can be secured on standstill using its internal electronics so that even when power is being supplied, the drive shaft is protected against unintentional restart. The chapter "Personnel safe restart lock -AS-" describes how to use the restart lock -AS-. See page 91 onwards.

6.7.1 Behavior in standard operation

The behavior of the servo amplifier always depends on the current setting of a number of different parameters (e.g., ACTFAULT, VBUSMIN, VELO, STOPMODE, etc.; see [online help](#)). The diagram below illustrates the correct functional sequence for switching the servo amplifier on and off.

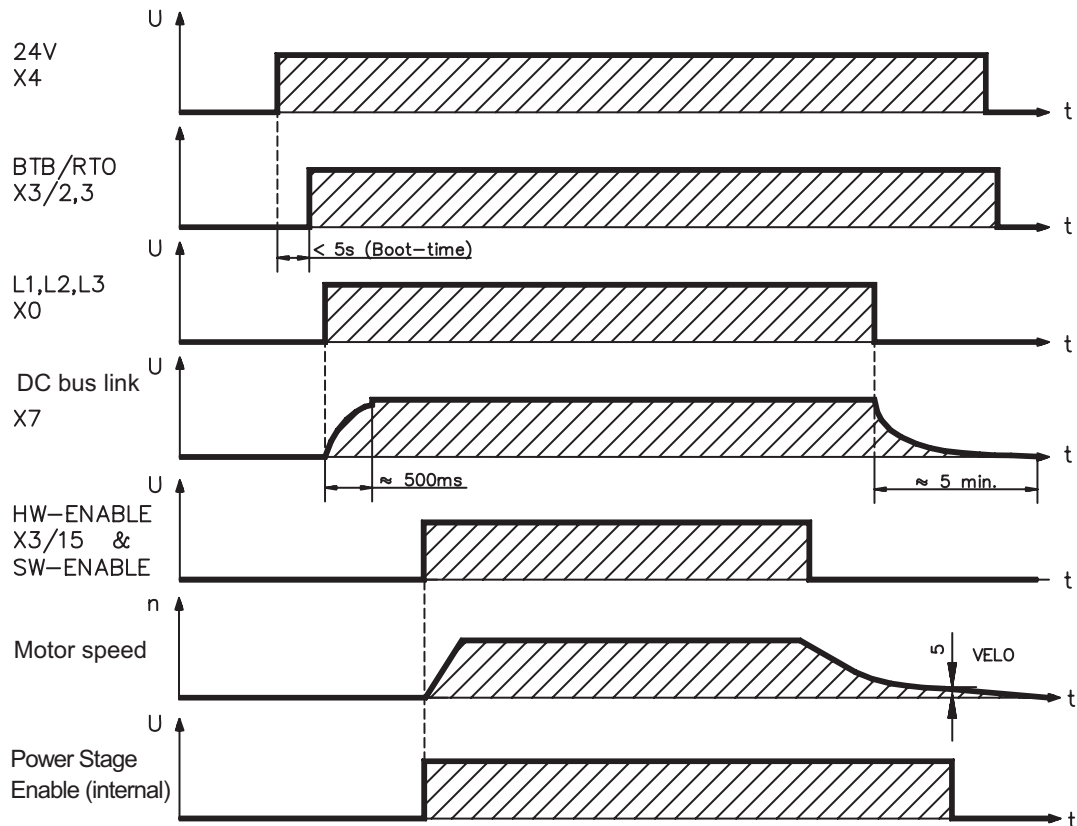

Devices which are equipped with a selected "Brake" function use a special sequence for switching off the output stage (⇒ p.26).

The -AS- option can be used to switch off the drive via a positive-action (approved by the Trade Liability Association) safety relay, so that personnel safety is ensured at the drive shaft (⇒ p.91).

6.7.2 Behavior in the event of an error (with standard setting)

The behavior of the servo amplifier always depends on the current setting of a number of different parameters (e.g., ACTFAULT, VBUSMIN, VELO, STOPMODE, etc.; see [online help](#)). The diagram shows the startup procedure and the procedure that the internal control system follows in the event of one or more electrical supply phases failing, assuming that the standard parameter settings apply.

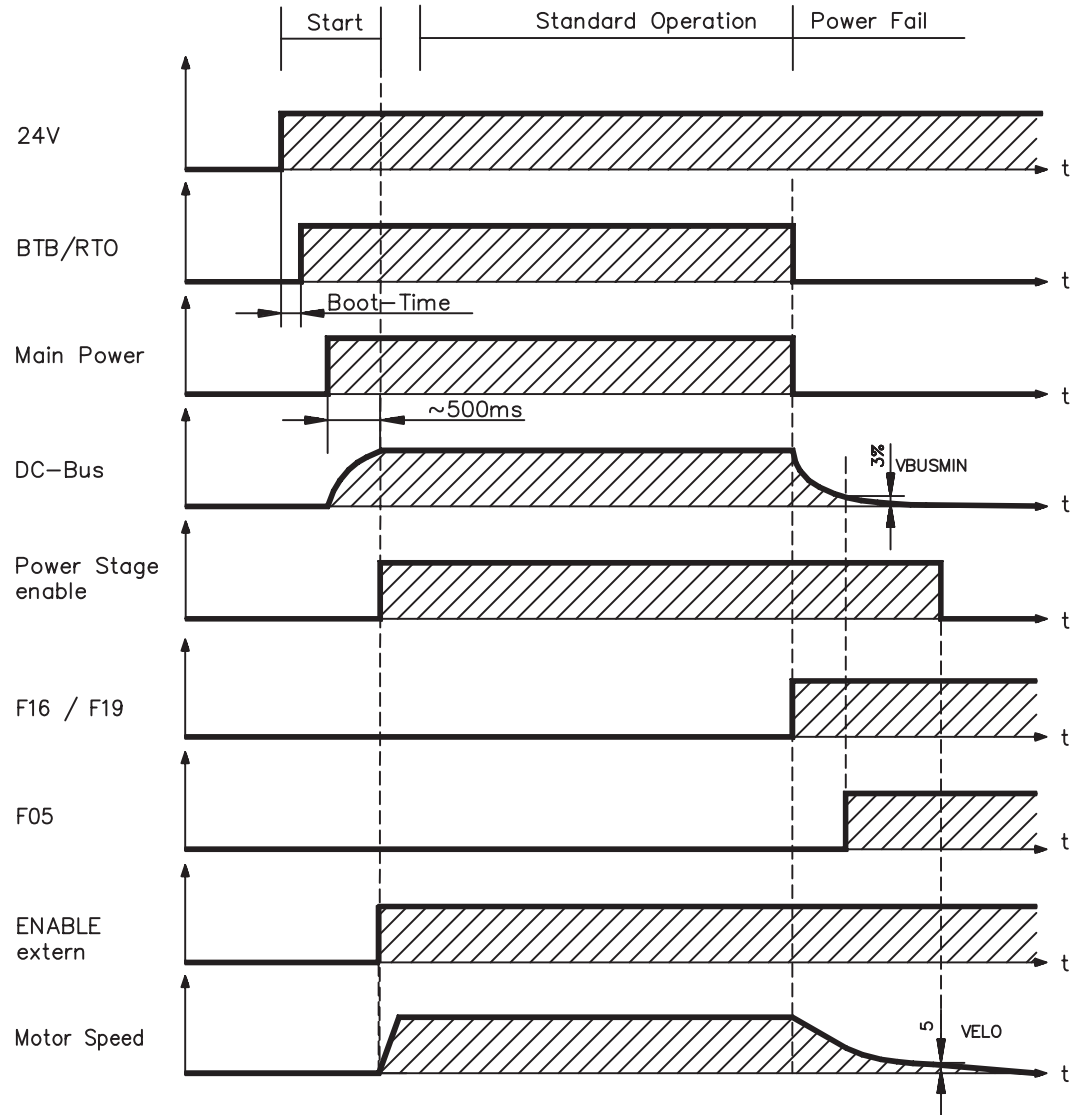

(F16/F19 = error messages Mains BTB /input phase, F05 = error message Undervoltage)

Even if there is no intervention from an external control system (in the example, the ENABLE signal remains active), the motor is immediately braked using the emergency stop ramp if an input phase error is detected and assuming that no changes have been made to the factory setting (ACTFAULT=1).

6.8 Stop/Emergency Stop Function to EN 60204

NOTE

With the personnel safe restart lock –AS- (see page 91 onwards) the drive can be secured on standstill (torque-free) using its internal electronics so that even when power is being supplied, the drive shaft is protected against unintentional restart.

Examples for implementation can be found in the Product WIKI on page "[Stop and Emergency Stop Function](#)".

6.8.1 Stop: Standards

The Stop function is used to shut down the machine in normal operation. The Stop functions are defined by EN 60204.

- Category 0:** Shut-down by immediate switching-off of the energy supply to the drive machinery (i.e. an uncontrolled shut-down);
- Category 1:** A controlled shut-down, whereby the energy supply to the drive machinery is maintained to perform the shut-down, and the energy supply is only interrupted when the shut-down has been completed;
- Category 2:** A controlled shut-down, whereby the energy supply to the drive machinery is maintained.

NOTE

The parameters “STOPMODE” and “ACTFAULT” must be set to 1 in order to implement the stop categories. If necessary, change the parameters via the terminal screen of the setup software and store the data in the EEPROM.

The Stop Category must be determined by a risk evaluation of the machine. In addition, suitable means must be provided to guarantee a reliable shut-down.

Category 0 and Category 1 Stops must be operable independently of the operating mode, whereby a Category 0 Stop must have priority. Stop functions must be implemented by **disconnection** of the appropriate circuitry, and have priority over assigned start functions.

If necessary, provision must be made for the connection of protective devices and lock-outs. If applicable, the Stop function must signal its status to the control logic. A reset of the Stop function must not create a hazardous situation.

Examples for implementation can be found in the Product WIKI on page "[Stop and Emergency Stop Function](#)".

6.8.2 Emergency Stop: Standards

The emergency Stop function is used for the **fastest possible shut-down** of the machine in a dangerous situation. The Emergency Stop function can be triggered by the actions of a single person. It must be fully functional and available at all times. The user must not have to work out how to operate this mechanism.

The Emergency Stop function is defined by EN 60204.

In addition to the requirements for Stop, the emergency Stop must fulfil the following requirements:

- emergency stop must have priority over all other functions and controls in all operating situations;
- the energy supply to any drive machinery that could cause dangerous situations must be switched off as fast as possible, without causing any further hazards (e.g. by using mechanical latching devices that do not require an external supply of energy, by counter-current braking in Stop Category 1);
- the reset must not initiate a restart.

If necessary, provision must be made for the additional connection of emergency stop devices (see EN 60204, "Requirements for emergency stop devices").

The Emergency Stop must be effective as a stop of either Category 0 or Category 1. The Emergency Stop Category must be determined by a risk evaluation of the machine.

Category 0

Only hard-wired, electromechanical components may be used for the Category 0 Emergency Stop function. It must not be triggered using switching logic (hardware or software), by transferring commands via a communication network, or via a data link.

The drive must be shut down using an electromechanical circuit. If the connected servo motor has an integrated brake, this must always be controlled by an electromechanical circuit as well.

Category 1

With the Category 1 Emergency Stop function, there must be absolute certainty in terms of the power supply for the machine drives being switched off (i.e., secured) using electromechanical components. Additional Emergency Stop equipment may be connected. Bringing the motor to a standstill by interrupting the mains supply and using controlled electronic braking. The 24 V supply for the servo amplifier must remain constant. The issue of which circuit should be used is highly dependent on the requirements of the application at hand.

Usually a brake in a servo motor only has the function of a holding brake. To ensure an emergency stop function, the braking torque that is required must be checked. If the holding brake fulfills the dynamic requirements, it must be taken into account that this application will cause increased wear.

NOTE

The parameters "STOPMODE" and "ACTFAULT" must be set to 1 in order to implement the stop categories. If necessary, change the parameters via the terminal screen of the setup software and store the data in the EEPROM.

Examples for implementation can be found in the Product WIKI on page "[Stop and Emergency Stop Function](#)".

6.9 Shock-hazard protection

6.9.1 Leakage current

Leakage current via the PE conductor results from the combination of equipment and cable leakage currents. The leakage current frequency pattern comprises a number of frequencies, whereby the residual-current circuit breakers definitively evaluate the 50Hz current. For this reason, the leakage current cannot be measured using a conventional multimeter.

As a rule of thumb, the following assumption can be made for leakage current on our low-capacity cables at a mains voltage of 400 V, depending on the clock frequency of the output stage:

$$I_{leak} = n \times 20mA + L \times 1mA/m \text{ at 8kHz clock frequency at the output stage}$$

$$I_{leak} = n \times 20mA + L \times 2mA/m \text{ at a 16kHz clock frequency at the output stage}$$

(where I_{leak} =leakage current, n=number of amplifiers, L=length of motor cable)

At other mains voltage ratings, the leakage current varies in proportion to the voltage.

Example: 2 x servo amplifiers + a 25m motor cable at a clock frequency of 8kHz:
 $2 \times 20mA + 25m \times 1mA/m = 65mA$ leakage current.

NOTE

Since the leakage current to PE is more than 3.5 mA, in compliance with EN61800-5-1 the PE connection must either be doubled or a connecting cable with a cross-section >10mm² must be used. Use the PE terminals (X0A and X0B) or the PE bolt in order to fulfil this requirement.

The following measures can be used to minimise leakage currents.

- Reduce the length of the engine cable
- Use low-capacity cables (see p.42)
- Avoid mains asymmetries (with an isolating transformer)

6.9.2 Residual-current circuit breakers (FI)

In conformity with DIN IEC 60364-4-41 – Regulations for installation and EN 60204 – Electrical equipment of machinery, residual-current circuit-breakers (called FI below) can be used provided the requisite regulations are complied with.

The SERVOSTAR 600 is a 3-phase system with a B6 bridge. Therefore, **FIs which are sensitive to all currents** must be used in order to detect any d.c. fault current. Refer to chapter 6.9.1 for the rule of thumb for determining the leakage current.

Rated residual currents in the FI

10 -30 mA	Protection against "indirect contact" (personal fire protection) for stationary and mobile equipment, as well as for "direct contact".
50 -300 mA	Protection against "indirect contact" (personal fire protection) for stationary equipment

NOTE

Recommendation: In order to protect against direct contact (with motor cables shorter than 5 m) we recommend that each servo amplifier be protected individually using a 30mA residual-current circuit-breaker which is sensitive to all currents.

If you use a selective FI circuit-breaker, the more intelligent evaluation process will prevent spurious tripping of the circuit-breakers.

6.9.3 Isolating transformers

If protection against indirect contact is absolutely essential despite a higher leakage current, or if an alternative form of shock-hazard protection is sought, the SERVOSTAR 600 can also be operated via an isolating transformer. A ground-leakage monitor can be used to monitor for short circuits.

NOTE

We would advise you to keep the length of wiring between the transformer and the servo amplifier as short as possible.

7 Mechanical Installation

7.1 Safety Instructions

⚠ CAUTION There is a danger of electrical shock by high EMC level which could result in injury, if the servo amplifier (or the motor) isn't properly EMC-grounded. Do not use painted (i.e. non-conductive) mounting plates.

NOTICE

Protect the servo amplifier from impermissible stresses. In particular, do not let any components become bent or any insulation distances altered during transport and handling. Avoid contact with electronic components and contacts.

NOTICE

The servo amplifier will switch-off itself in case of overheating. Ensure that there is an adequate flow of cool, filtered air into the bottom of the control cabinet, or use a heat exchanger. Please refer to page 24.

NOTICE

Don't mount devices, which produce magnetic fields, directly beside the servo amplifier. Strong magnetic fields could directly affect internal components. Install devices which produce magnetic field with distance to the servo amplifiers and/or shield the magnetic fields.

7.2 Guide to mechanical installation

The following notes should assist you to carry out the mechanical installation in a sensible sequence, without overlooking anything important.

Site	In a closed switchgear cabinet. Observe page 24 . The site must be free from conductive or corrosive materials. For the mounting position in the cabinet ⇒ p. 36
Ventilation	Check that the ventilation of the servo amplifier is unimpeded and keep within the permitted ambient temperature ⇒ p. 24 . Keep the required space clear above and below the servo amplifier ⇒ p 36.
Assembly	Assemble the servo amplifier and power supply, filter and choke close together on the conductive, grounded mounting plate in the cabinet.
Grounding Shielding	EMC-compliant (EMI) shielding and grounding (⇒ p. 47) Earth (ground) the mounting plate, motor housing and CNC-GND of the controls. Notes on connection techniques are on page 42

7.3 Assembly

Material : 2 or 4 hexagon socket screws to EN 4762, M5
 Tool required : 4 mm Allen key

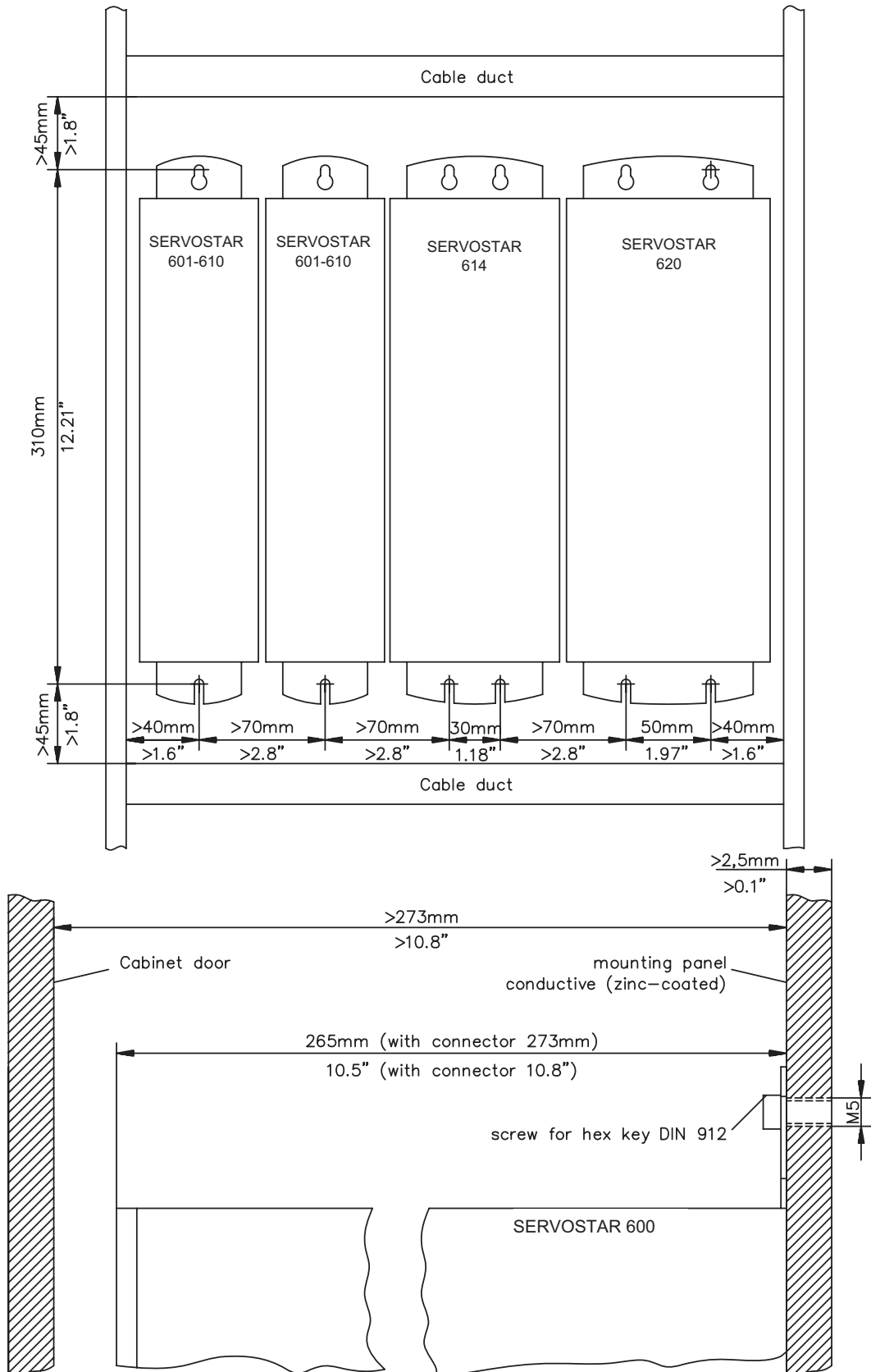

7.4 Dimensions

SERVOSTAR 601/603/603/610

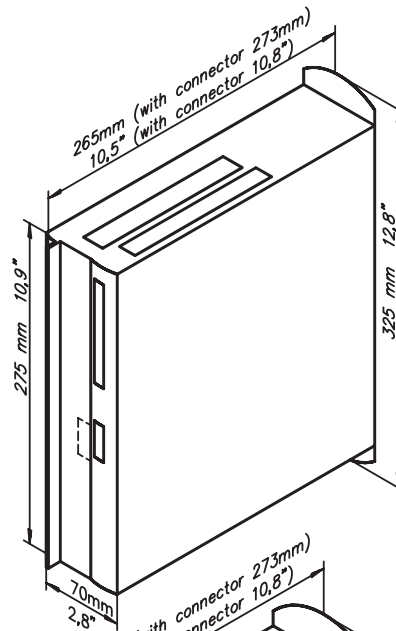

SERVOSTAR 614

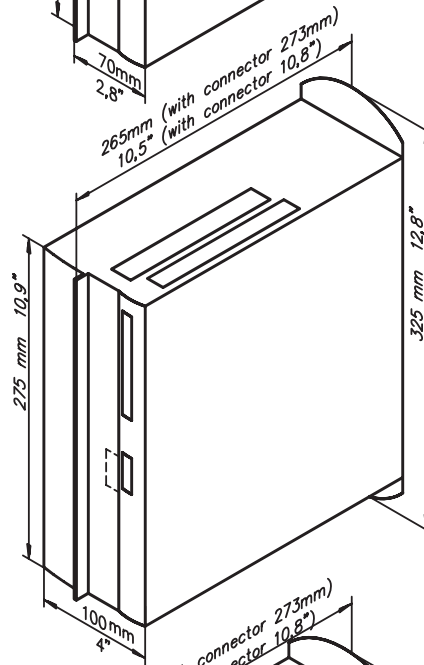

SERVOSTAR 620

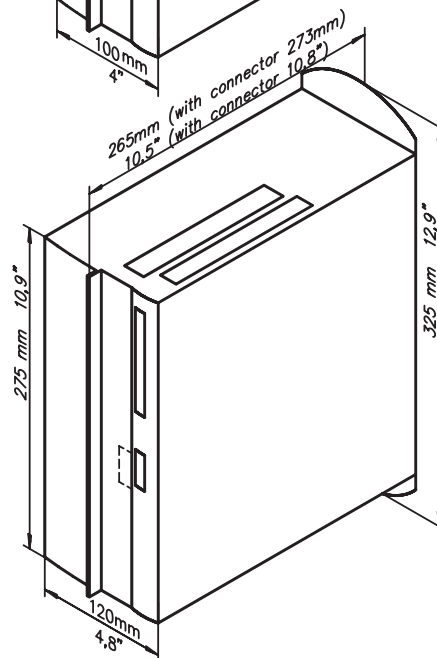

This page has been deliberately left blank.

8 Electrical Installation

8.1 Safety Instructions

⚠ DANGER

Never undo any electrical connections to the servo amplifier while it is live. There is a danger of electrical arcing with damage to contacts and serious personal injury. Wait at least five minutes after disconnecting the servo amplifier from the main supply power before touching potentially live sections of the equipment (e.g. contacts) or undoing any connections.

Capacitors can still have dangerous voltages present up to five minutes after switching off the supply power. To be sure, measure the voltage in the DC Bus link and wait until it has fallen below 40V.

Control and power connections can still be live, even if the motor is not rotating.

NOTICE

Wrong mains voltage, unsuitable motor or wrong wiring will damage the amplifier.

Check the combination of servo amplifier and motor. Compare the rated voltage and current of the units. Implement the wiring according to the connection diagram on page 41.

Make sure that the maximum permissible rated voltage at the terminals L1, L2, L3 or +DC, -DC is not exceeded by more than 10% even in the most unfavorable circumstances (see IEC 60204-1).

NOTICE

Excessively high external fusing will endanger cables and devices. The fusing of the AC supply input and 24V supply must be installed by the user, best values are given on p.24. Hints for use of Residual-current circuit breakers (FI) ⇒ p.34.

NOTICE

Correct wiring is the basis for reliable functioning of the servo system.

Route power and control cables separately. We recommend a distance of at least 200mm.

This improves the interference immunity. If a motor power cable is used that includes cores for brake control, the brake control cores must be separately shielded. Ground the shielding at both ends. Ground all shielding with large areas (low impedance), with metalized connector housings or shield connection clamps wherever possible. Notes on connection techniques can be found on page 42.

NOTICE

Feedback lines may not be extended, since thereby the shielding would be interrupted and the signal processing could be disturbed. Lines between amplifiers and external brake resistor must be shielded. Install all power cables with an adequate cross-section, as per IEC 60204 (⇒ p.25) and use the requested cable material (⇒ p. 42) to reach max. cable length.

NOTICE

The servo amplifier's status must be monitored by the PLC to acknowledge critical situations. Wire the BTB/RTO contact in series into the emergency stop circuit of the installation. The emergency stop circuit must operate the supply contactor.

NOTE

It is permissible to use the setup software to alter the settings of the servo amplifier. Any other alterations will invalidate the warranty.

8.2 Guide to electrical installation

The following notes should assist you to carry out the electrical installation in a sensible sequence, without overlooking anything important.

Cable selection

Select cables according to EN 60204 (⇒ p. 25)

Grounding Shielding

EMC-compliant (EMI) shielding and grounding (⇒ p. 47)
Earth (ground) the mounting plate, motor housing and CNC-GND of the controls.
Notes on connection techniques are on page 42

Wiring

Route power leads and control cables separately
Wire the BTB/RTO contact in series into the emergency stop circuit of the system.

- Connect the digital control inputs to the servo amplifier
- Connect up AGND (also if fieldbuses are used)
- Connect the analog setpoint, if required
- Connect up the feedback unit (resolver and/or encoder)
- Connect the encoder emulation, if required
- Connect the expansion card (see hints from page 98)
- Connect the motor cables, connect shielding to EMI connectors at both ends
- Use motor chokes (3YL) for lead lengths >25m
- Connect the external brake resistor (with fusing) if required
- Connect aux. supply (for max. permissible voltage values ⇒ p. 24)
- Connect main power supply (for max. permissible voltage values ⇒ p. 24)
- Connect PC (⇒ p. 69).

Final check

- Final check of the implementation of the wiring, according to the wiring diagrams which have been used.

8.3 Wiring

The installation procedure is described as an example. A different procedure may be sensible or necessary, depending on the application of the equipment.

We provide further know-how through **training courses** (on request).

8.3.1 Safety Instructions

⚠ DANGER There is a danger of electrical arcing with serious personal injury. Only install and wire up the equipment when it is not live, i.e. when neither the electrical supply nor the 24 V auxiliary voltage nor the supply voltages of any other connected equipment is switched on. Take care that the cabinet is safely disconnected (with a lock-out, warning signs etc.). The individual voltages will be switched on for the first time during setup.

⚠ CAUTION Only professional staff who are qualified in electrical engineering are allowed to install the servo amplifier.

NOTE

The ground symbol \llcorner , which you will find in all the wiring diagrams, indicates that you must take care to provide an electrically conductive connection with the largest possible surface area between the unit indicated and the mounting plate in the switchgear cabinet. This connection is for the effective grounding of HF interference, and must not be confused with the PE- symbol \perp (a protective measure to EN 60204).

NOTE

Use the following connection diagrams:

Overview	: page 47
Mains power	: page 49
Motor	: page 50
Feedback	: page 51ff
Electronic Gearing / Master Slave	
Master-Slave	: page 58
Pulse-Direction	: page 61
Encoder Emulation:	
ROD (A quad B)	: page 63
SSI	: page 64
Digital/Analog I/Os	: page 65ff
RS232 / PC	: page 69
CAN Interface	: page 70
Multi-axis systems, example	: page 85
Restart lock option -AS-	: page 94
Expansion cards:	
I/O-14/08	: page 101
PROFIBUS	: page 102
SERCOS	: page 104
DeviceNet	: page 105
EtherCAT	: page 108
SynqNet	: page 110
-2CAN-	: page 112

8.3.2 Technical data for connecting cables

Further information on the chemical, mechanical and electrical characteristics of the cables can be obtained from our customer service.

NOTE Observe the restrictions in the chapter "Conductor cross-sections" on page 25. To reach the max. permitted cable length, you must use cable material that matches the capacitance requirements listed below.

Insulation material

Sheathing	PUR (polyurethane, code 11Y)
Core insulation	PETP (polyesteraphtalate, code 12Y)

Capacitance

Motor cable	less than 150 pF/m
RES-/Encoder-cable	less than 120 pF/m

Technical data

For a detailed description of cable types and how to assemble them, please refer to the accessories manual.

NOTE Motor cables longer than 25m with motor choke 3YL only.

8.3.3 Shielding connection to the front panel

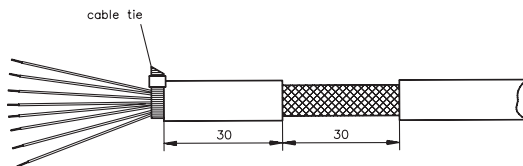

Remove the outer covering of the cable and the shielding braid from the cores for the required length. Secure the cores with a cable tie.

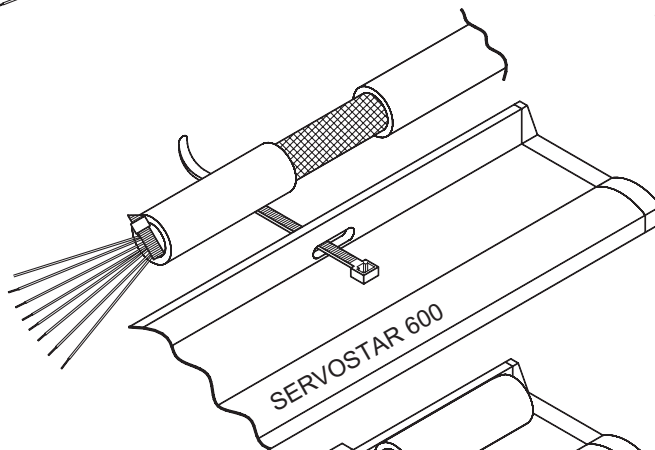

Remove the outer covering of the cable over a length of about 30mm, without damaging the shielding braid.

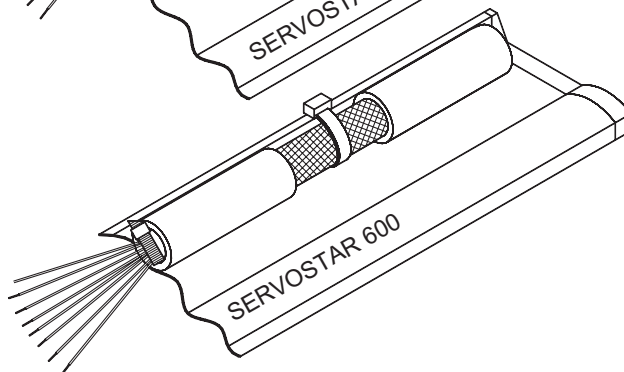

Pull a cable tie through the slot in the shielding rail (front panel) of the servo amplifier.

Use the cable tie to clamp the shielding braid of the cable firmly to the shielding rail.

8.3.4 Motor connector with shieldplate

The motor is connected to the SERVOSTAR 600 by a Power Combicon connector (X9). You can obtain the connector kit from us (connector, housing, shield plate, rubber bushes, installation material, order codes see p.117).

The cable material depends on the motor that is used. Please refer to the instructions manual for the corresponding motor series. Please take note that the connector can accept a maximum conductor cross-section of 4mm².

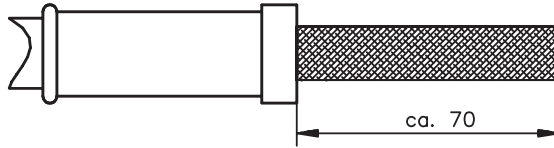

First push the rubber sleeve onto the cable, and **then** strip off about 70mm of the outer covering, without damaging the shielding.

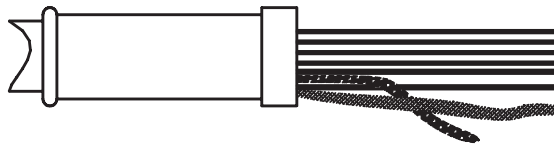

Carefully separate the shielding braid from the cores.

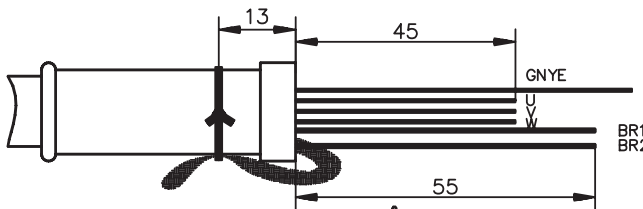

Twist the shielding braid into a pigtail and tie it to the sleeve with the wire. Shorten the brake cores to 55mm and the power cores to 45mm.

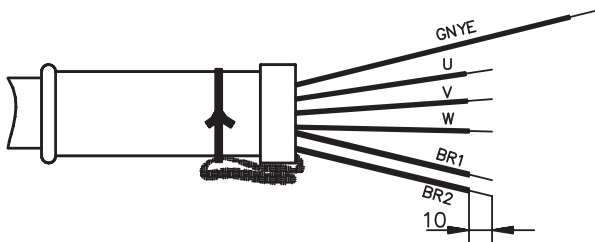

Fold back the overhanging length of the shielding pigtail to face forwards. Strip off the ends of the cores for about 10mm. This length can vary, depending on the type of bootlace ferrule that is used.

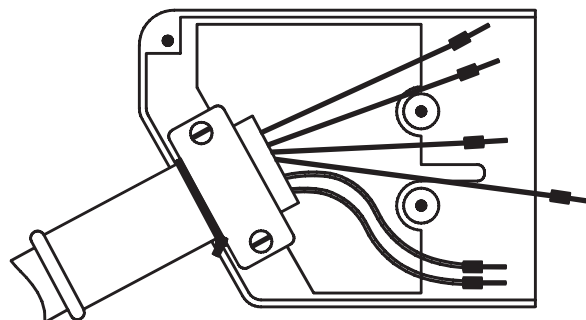

Apply bootlace ferrules to the conductors. Place the shield plate in the bottom half of the connector housing. Place the cable in the strain relief, so that the folded shielding pigtail lies on the shield plate, but the tie-wire is not clamped inside.

Tighten up the screws, without crushing the cable.

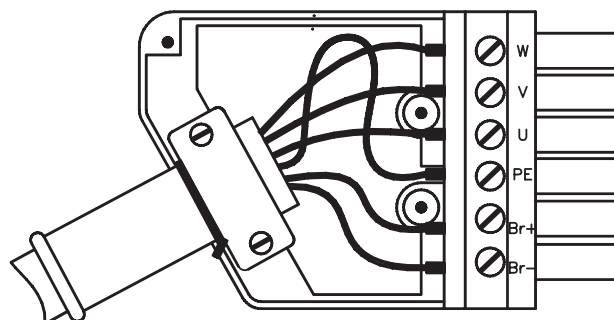

Place the connector in the housing. Take care that the tongue of the shield plate sits in the PE clamp. Wire up the connector according to the wiring diagram on page 50, and tighten up the clamping screws. Take care that the insulation is not trapped underneath. Close the housing.

8.4 Components of a servo system

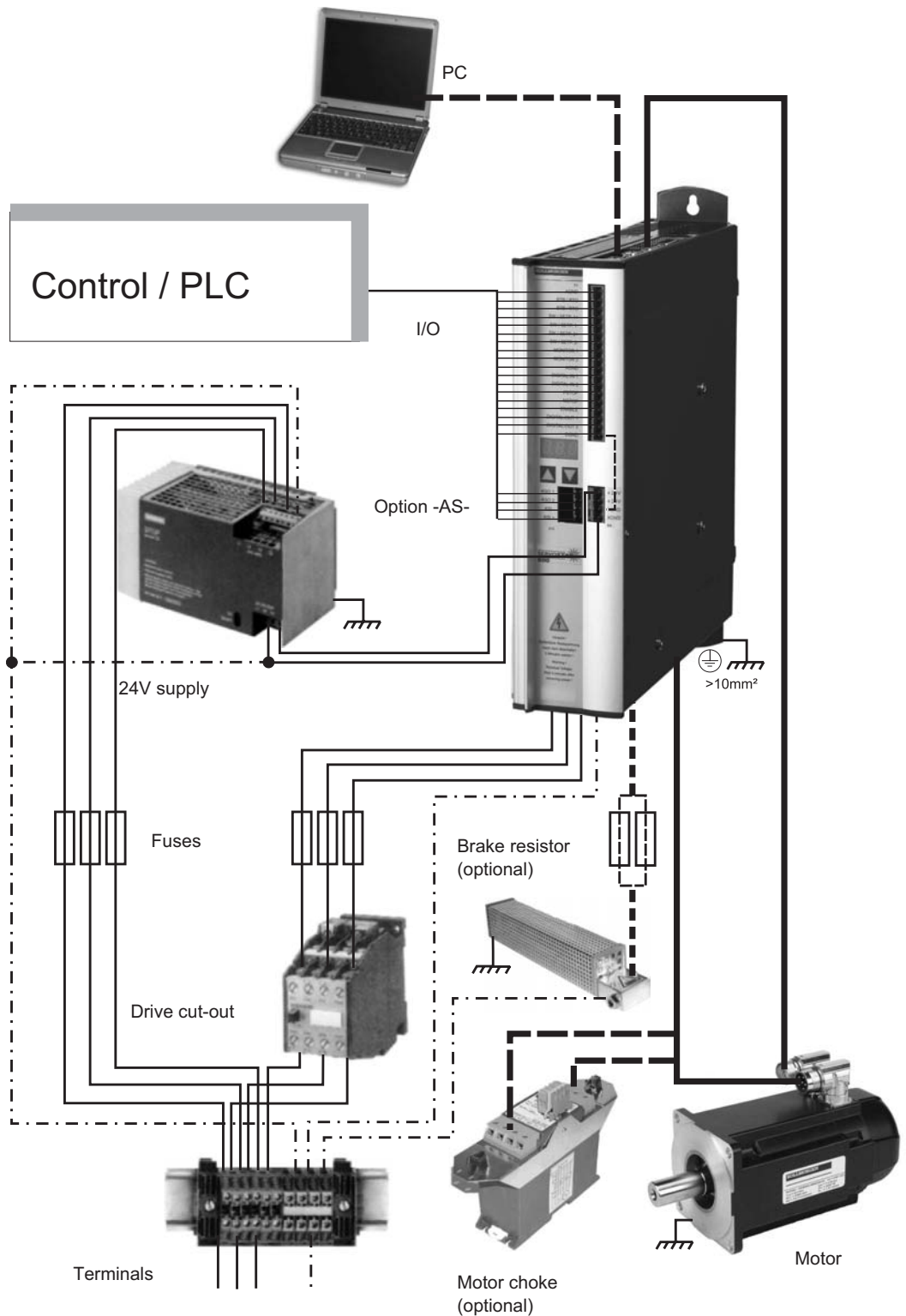

NOTE Cables drawn bold are shielded. Electrical ground is drawn with dash-dotted lines. Optional devices are connected with dashed lines to the servo amplifier. The required accessories are described in our accessories manual.

8.5 Block diagram

The block diagram below is just an overview.

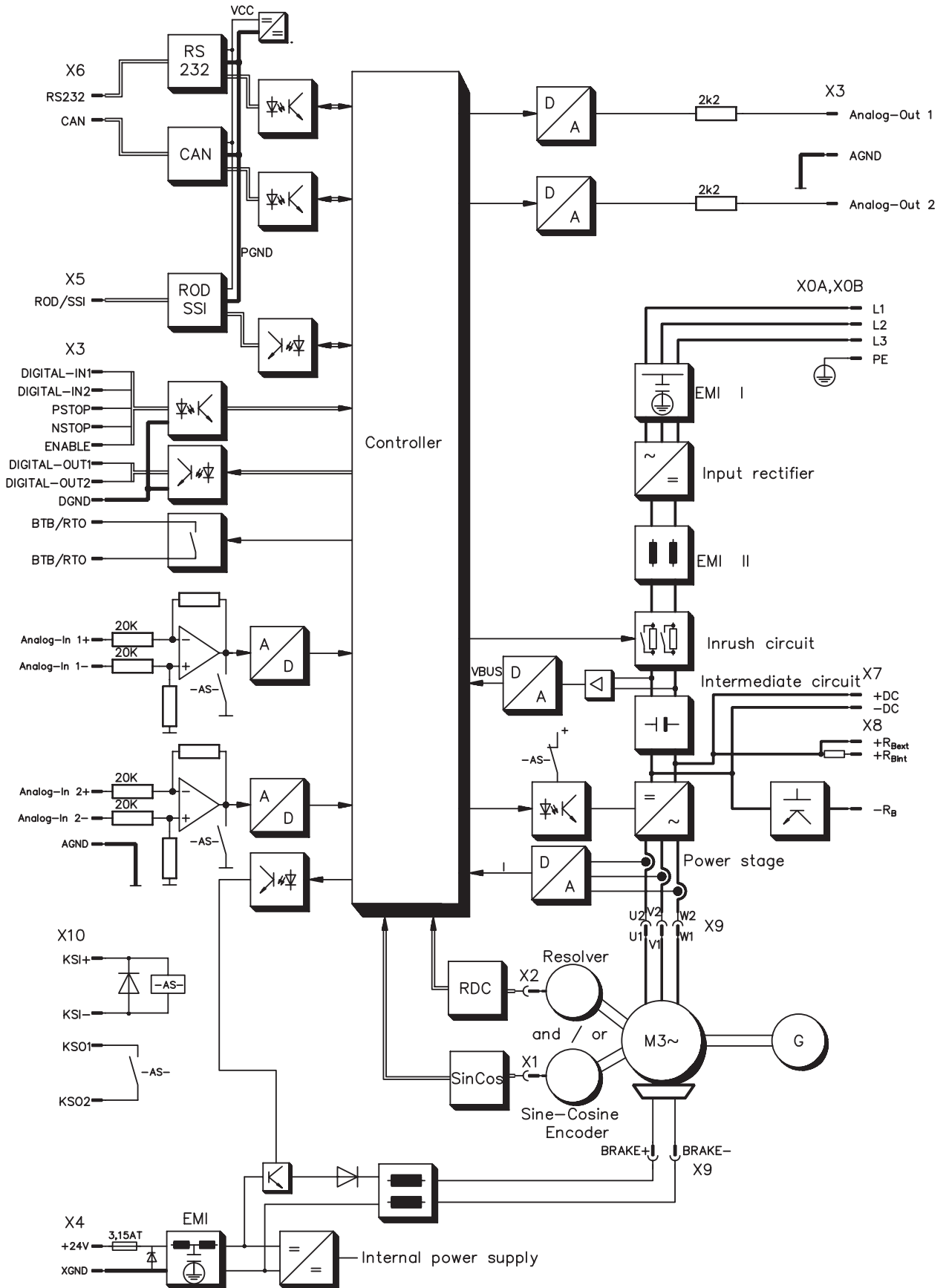

8.6 Pin assignments

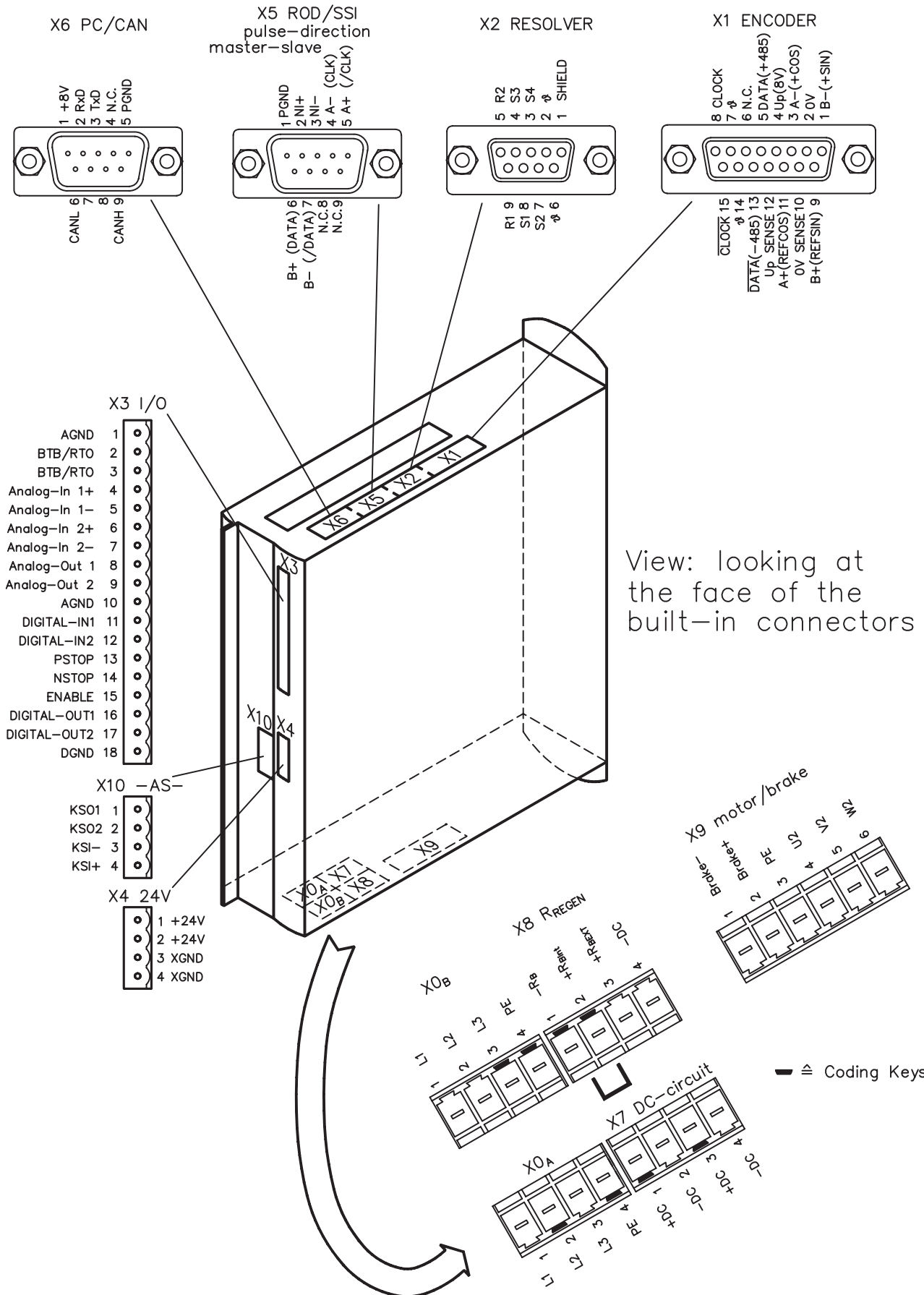

8.7 Connection diagram (overview)

Reference Safety Instructions (⇒ p.11) and Use As Directed (⇒ p.12) !

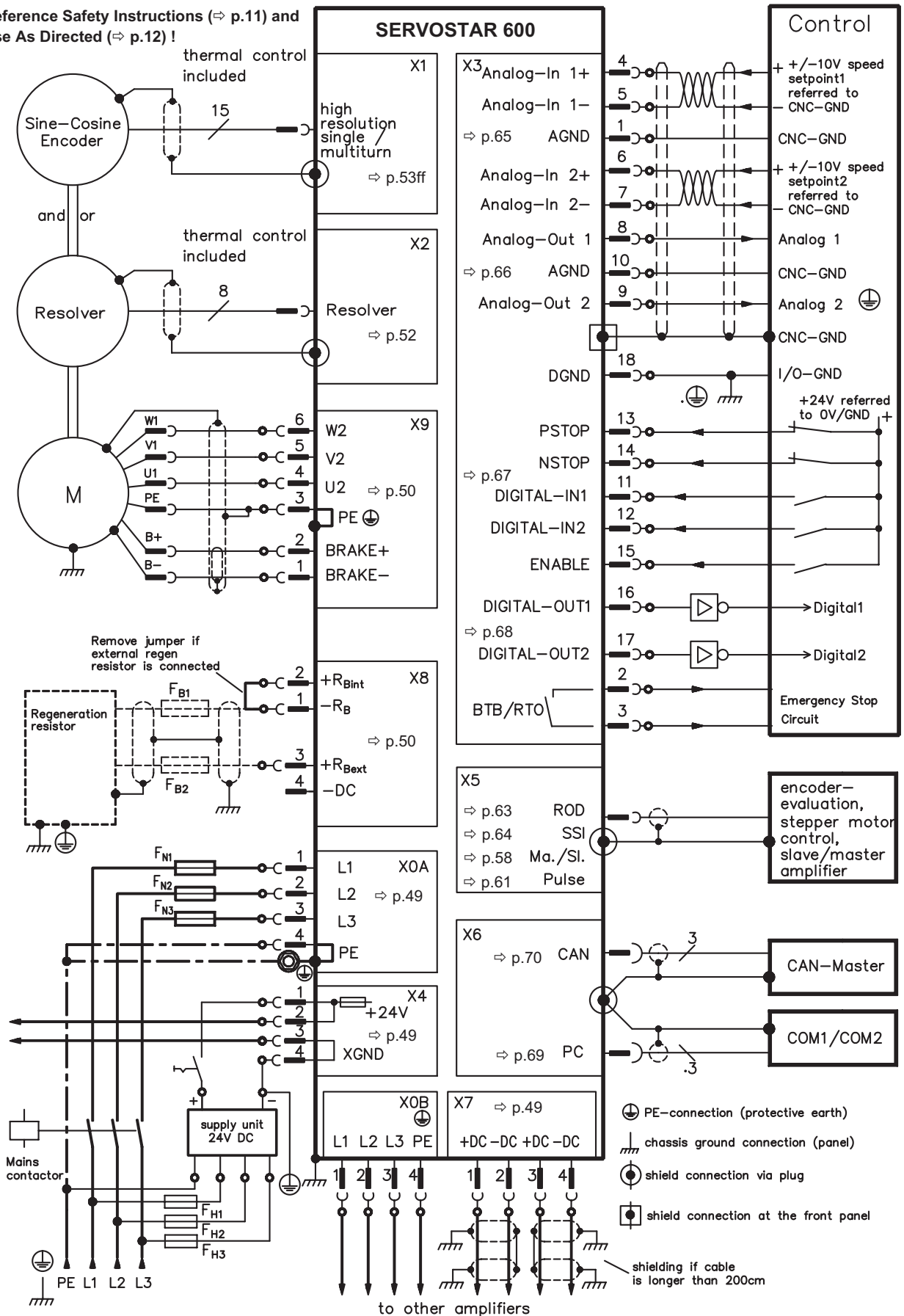

8.8 Power supply

8.8.1 Connection to various mains supply networks

This page illustrates all the possible connection variations for different electrical supply networks.

NOTICE An isolating transformer is always required for 400...480V mains networks without earth(ground) and for networks with asymmetrical earth(ground).

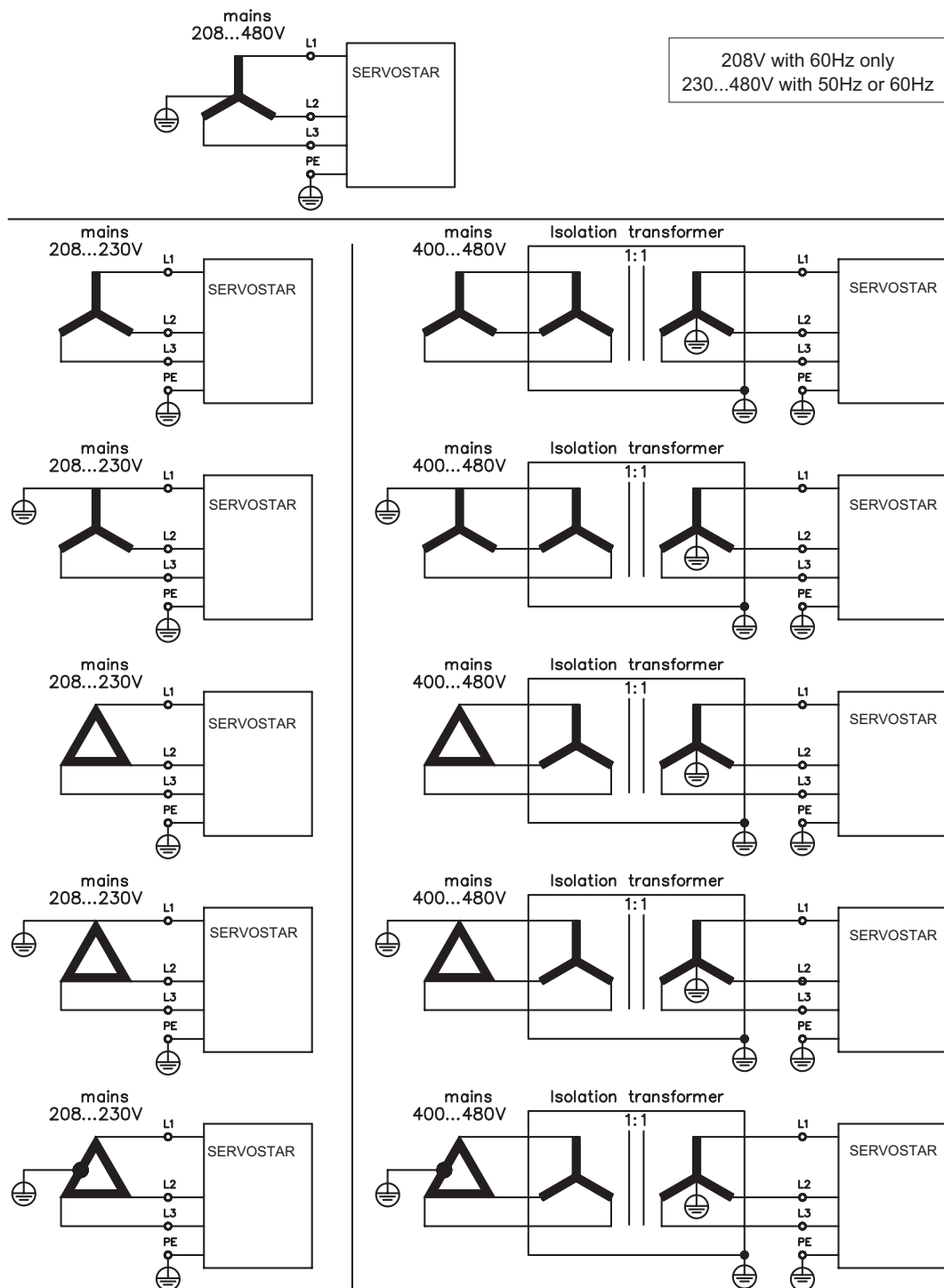

8.8.2 Mains supply connection (X0)

- Directly to earthed (grounded) 3~ supply, integrated EMI filter
- Fusing (e.g. fusible cut-outs) provided by the user ⇒ p.24

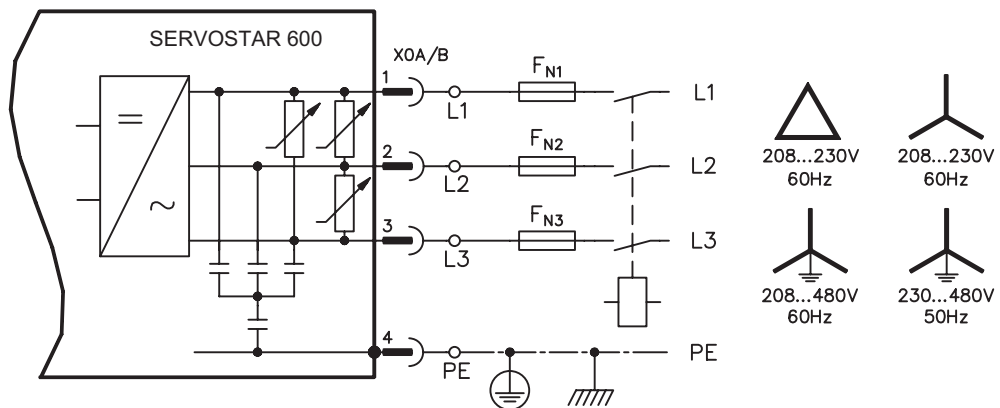

8.8.3 24V auxiliary supply (X4)

- Electrically isolated, external 24VDC supply, e.g. with insulating transformer
- Required current rating ⇒ p.23
- Integrated EMI filter for the 24V auxiliary supply

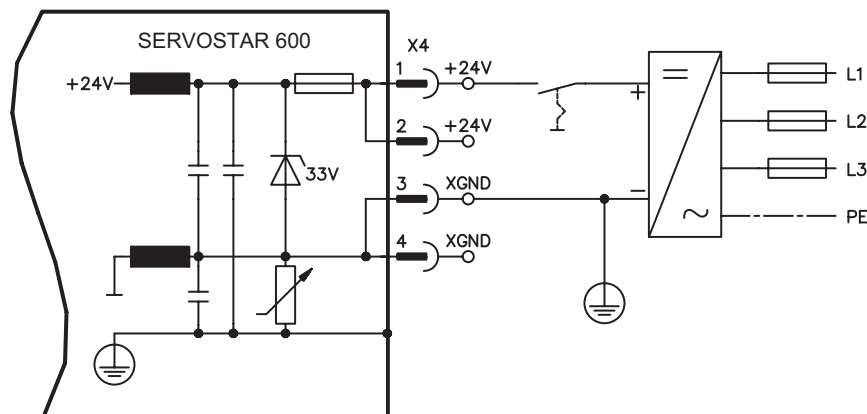

8.8.4 DC bus link (X7)

Can be connected in parallel. A patented circuit distributes the brake power among all the amplifiers connected to the same DC bus link circuit. (Connection example ⇒ p.72).

NOTICE

Only servo amplifiers with mains supply from the same mains (identical mains supply voltage) may be connected by the DC bus link.

The sum of the rated currents for all of the servo amplifiers connected in parallel to an SERVOSTAR 600 must not exceed 40A.

Use unshielded single cores (2.5mm²) with a max. length of 200 mm. Use shielded cables for longer lengths.

8.9 Motor connection with holding brake (X9)

Lead length ≤ 25m

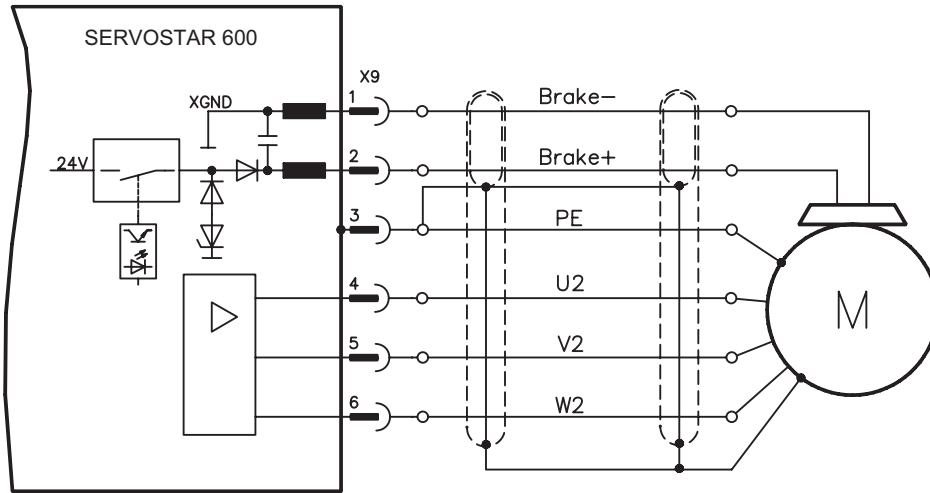

Lead length >25m

For lead lengths above 25m the choke box 3YL/3YLN (see accessories manual) must be wired into the motor lead, close to the amplifier.

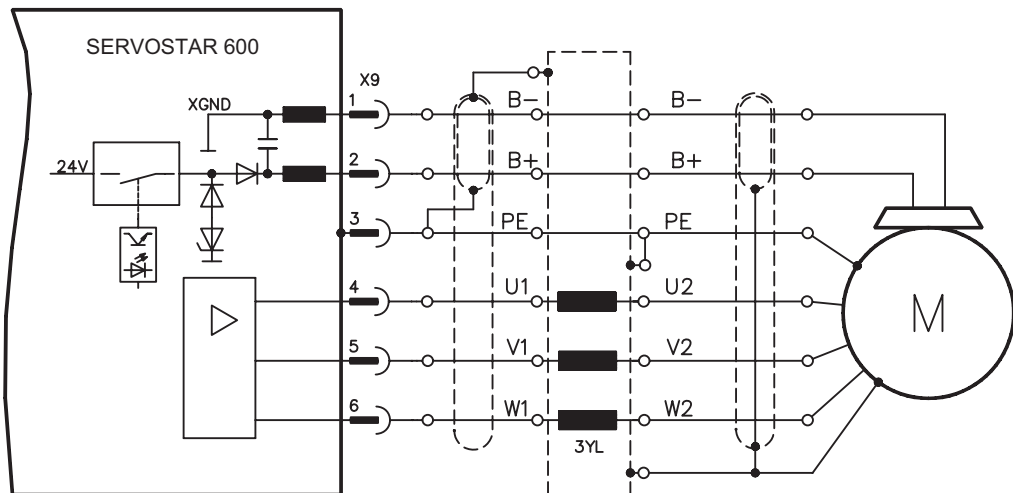

8.10 External brake resistor (X8)

Remove the plug-in link between the terminals X8/1 (-R_B) and X8/2 (+R_{Bint}).

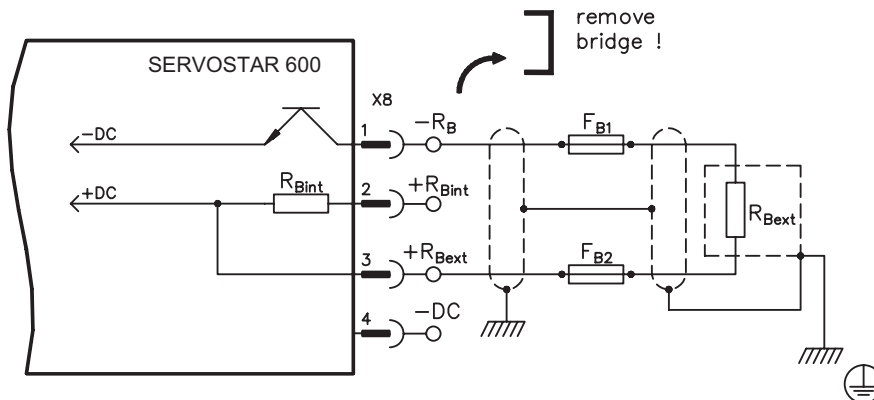

8.11 Feedback

Every closed servo system will normally require at least one feedback device for sending actual values from the motor to the servo drive. Depending on the type of feedback device used, information will be fed back to the servo amplifier using digital or analog means.

SERVOSTAR 600 supports the most common types of feedback device whose functions must be assigned with the parameters

FBTYPE (screen page FEEDBACK), primary Feedback

EXTPOS (screen page POSITION), secondary Feedback

GEARMODE (screen page GEARING), secondary Feedback

in the setup software. Scaling and other settings must always be made here.

Configuration	Location	ASCII Parameter	Commu- tation	Speed control	Position- control	electr. gearing
One Feedback	motor	FBTYPE	X	X	X	
Two Feedbacks	motor	FBTYPE	X	X		
	externally	EXTPOS			X	
		GEARMODE				X

For a detailed description of the ASCII parameters, please refer to the [online help](#) of the setup software.

The table below provides an overview of the supported feedback types, their corresponding parameters and a reference to the relevant connection diagram in each case. On each of these, the pin assignment shown on the encoder side relates to the Kollmorgen motors.

Primary feedback type	Connector	Wiring diagram	FBTYPE
Resolver	X2	⇒ p.52	0, 3
SinCos Encoder BISS	X1	⇒ p.53	20*
SinCos Encoder ENDAT	X1	⇒ p.54	3, 4
SinCos Encoder HIPERFACE	X1	⇒ p.54	2, 3
SinCos Encoder w/o data channel	X1	⇒ p.55	6, 7 (16*)
SinCos Encoder + Hall	X1	⇒ p.56	11*
RS422 5V + Hall	X1	⇒ p.56	12*
RS422 5V	X5	⇒ p.57	8*, 9*
Sensorless (w/o feedback)	-	-	10*

* Can only be set on the terminal screen of the setup software

** RS422 means "incremental encoder AquadB".

NOTE

Hints for combining primary with secondary feedback systems for position control/electr. gearing can be found from page 58.

8.11.1 Resolver (X2)

Connection of a Resolver (2 to 36-poles) as a feedback system (primary, ⇨ p.51). The thermal control in the motor is connected via the resolver cable to X2 and evaluated there.

If cable lengths of more than 100 meters are planned, please contact our customer service.

FBTYPE: 0, 3

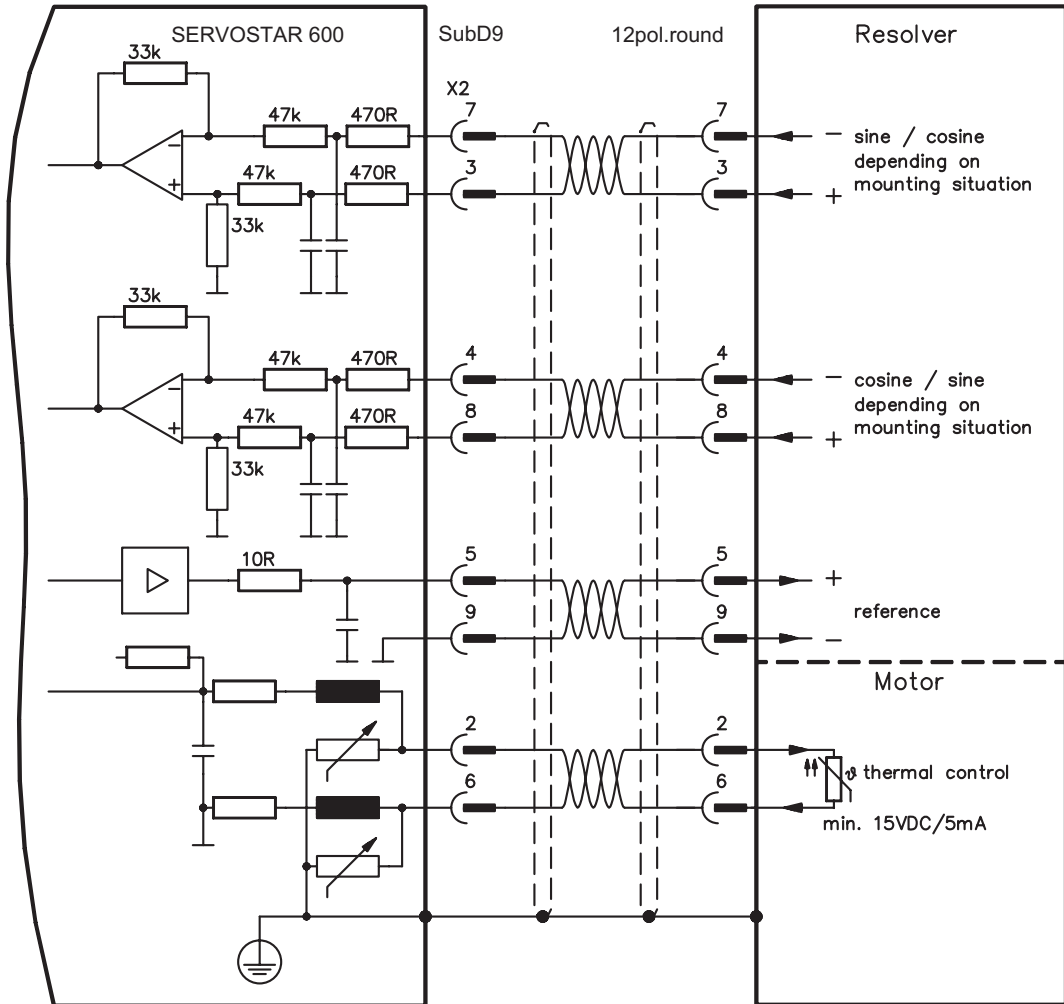

The pin assignment shown on the encoder side relates to the Kollmorgen motors.

8.11.2 Sine Encoder 5V with BiSS (X1)

Wiring of a single-turn or multi-turn sine-cosine encoder with BiSS interface as a feedback system (firmware revision from 6.68). During start-up of the servo amplifier the parameters stored in the encoder eeprom are uploaded, after that phase only the sine/cosine signals are used.

The thermal control in the motor is connected via the encoder cable to X1 and evaluated there. All signals are connected using our pre-assembled encoder connection cable.

Encoder types with a power consumption of more than 150mA can also be connected using our external power supply (⇒ p. 113). For encoders that do not have integrated terminating resistors, we offer an optional terminating adapter (⇒ p. 113).

If cable lengths of more than 50m are planned, please consult our customer service.

Frequency limit (sin, cos): 250 kHz
FBTYPE 20

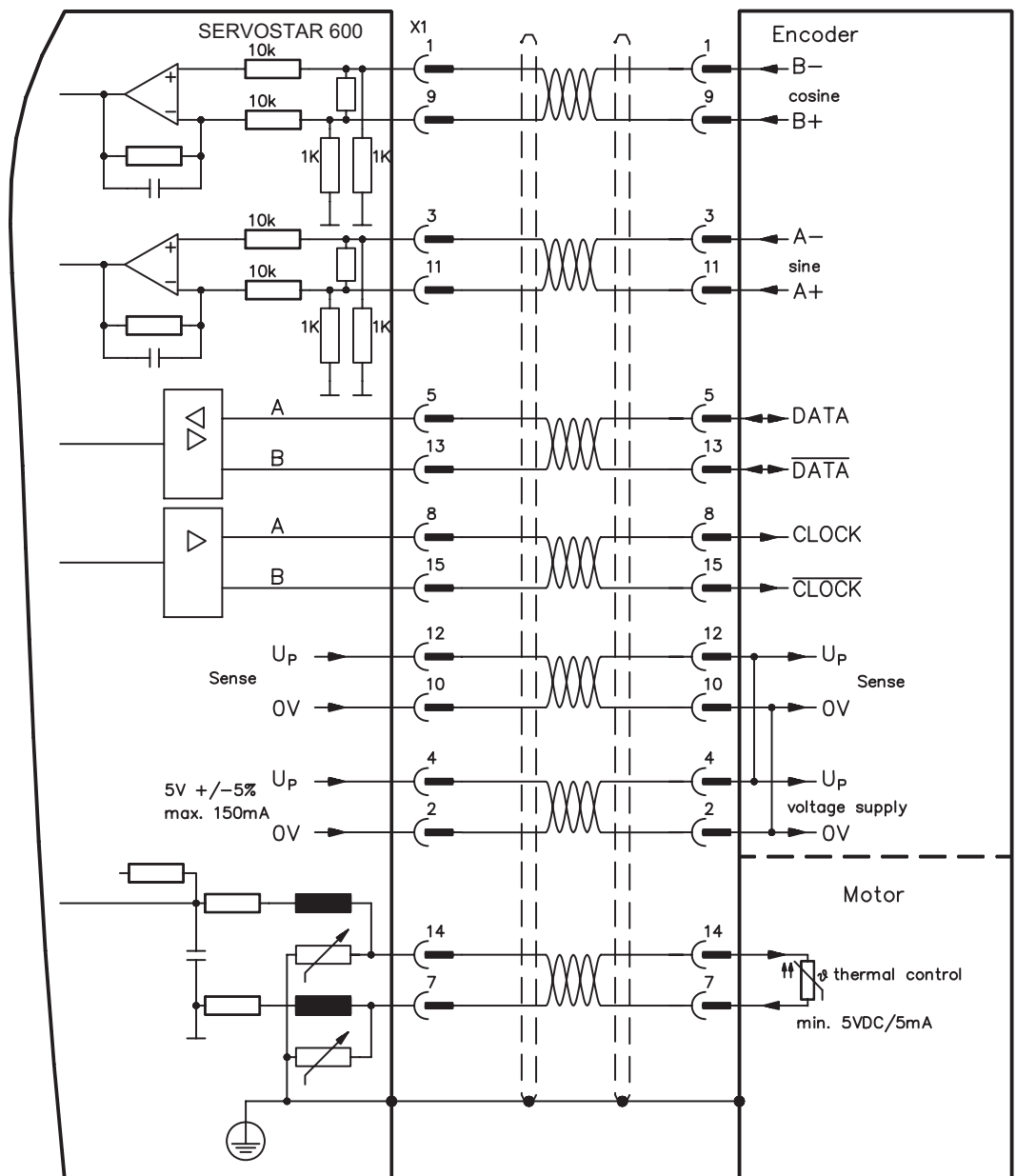

The pin assignment shown on the encoder side relates to the Kollmorgen motors.

8.11.3 Sine Encoder with EnDat 2.1 or HIPERFACE (X1)

Wiring of a single-turn or multiturn sine-cosine encoder as a feedback system. Preferred types are ECN1313 and EQN1325. The thermal control in the motor is connected via the encoder cable to the SERVOSTAR 600 and evaluated there. All signals are connected using our pre-assembled encoder connection cable.

Encoder types with a power consumption of more than 150mA can also be connected using our external power supply (⇒ p. 113). For encoders that do not have integrated terminating resistors, we offer an optional terminating adapter (⇒ p. 113).

If lead lengths of more than 50m are planned, please consult our customer service.

Frequency limit (sin, cos): 250 kHz

Encoder with EnDat: FBTYPE 3, 4

Encoder with HIPERFACE: FBTYPE 2, 3

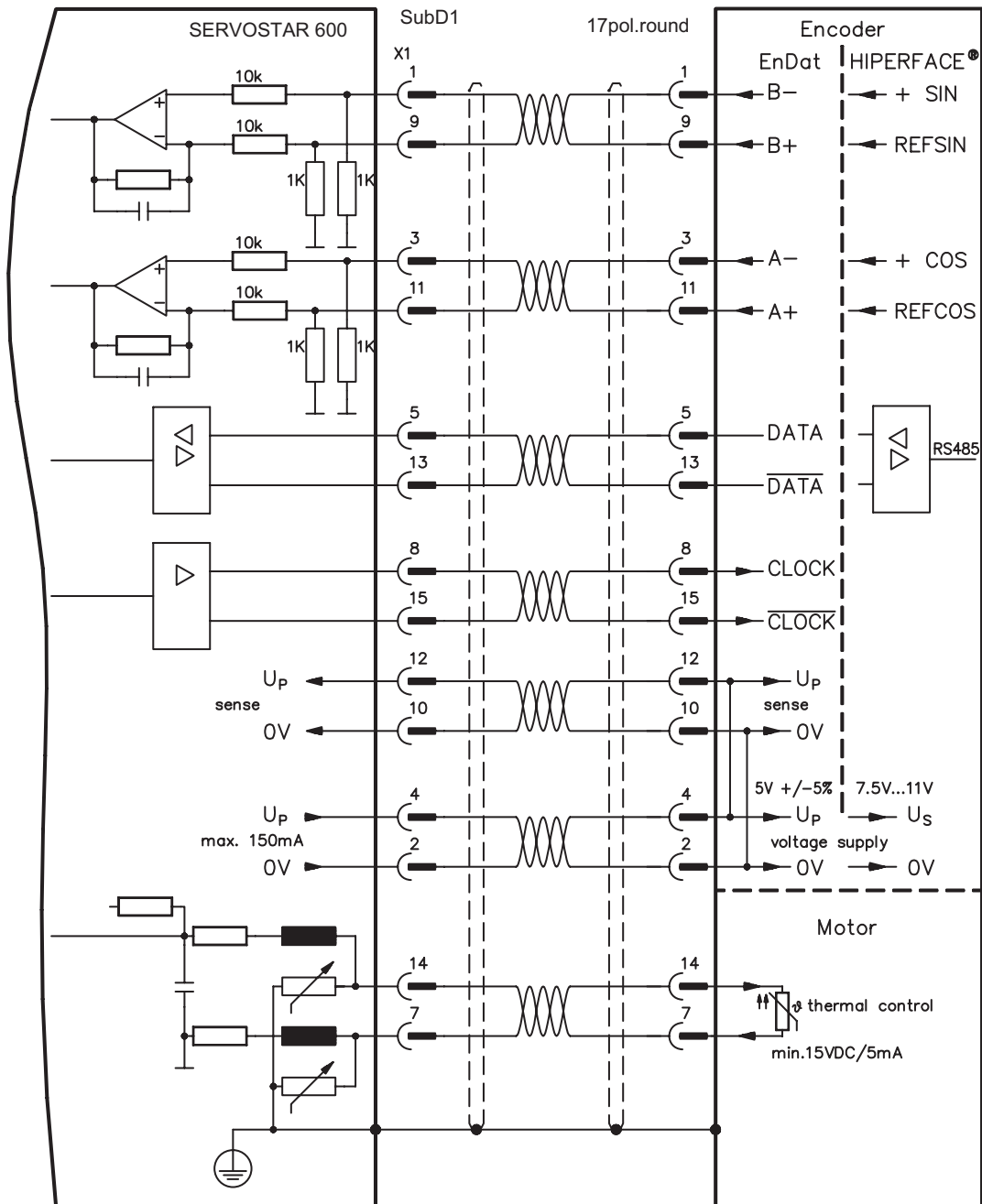

The pin assignment shown on the encoder side relates to the Kollmorgen motors.

8.11.4 Sine Encoder without data channel (X1)

Wiring of a sine-cosine encoder without data channel as standard feedback system. Every time the 24V auxiliary voltage is switched on, the amplifier needs start-up information for the position controller (parameter value MPHASE). Depending on the feedback type either wake&shake is executed or the value for MPHASE is read out of the amplifier's EEPROM.

Encoder types with a power consumption of more than 150mA can also be connected using our external power supply (⇒ p. 113). For encoders that do not have integrated terminating resistors, we offer an optional terminating adapter (⇒ p. 113).

The thermal control in the motor is connected via the encoder cable to X1 and evaluated there.

If lead lengths of more than 50m are planned, please consult our customer service.

Frequency limit (sin, cos): 250 kHz

Encoder type	FCTYPE	Remarks
SinCos 5V	6	MPHASE from EEPROM
SinCos 5V	7	MPHASE with wake & shake
Resolver+SinCos5V	16	Commutation with Resolver, speed&position with Encoder

⚠ WARNING With vertical load the load could fall during wake&shake, because the brake is not active and torque is not sufficient to hold the load. Don't use this feedback type with vertical load (hanging load).

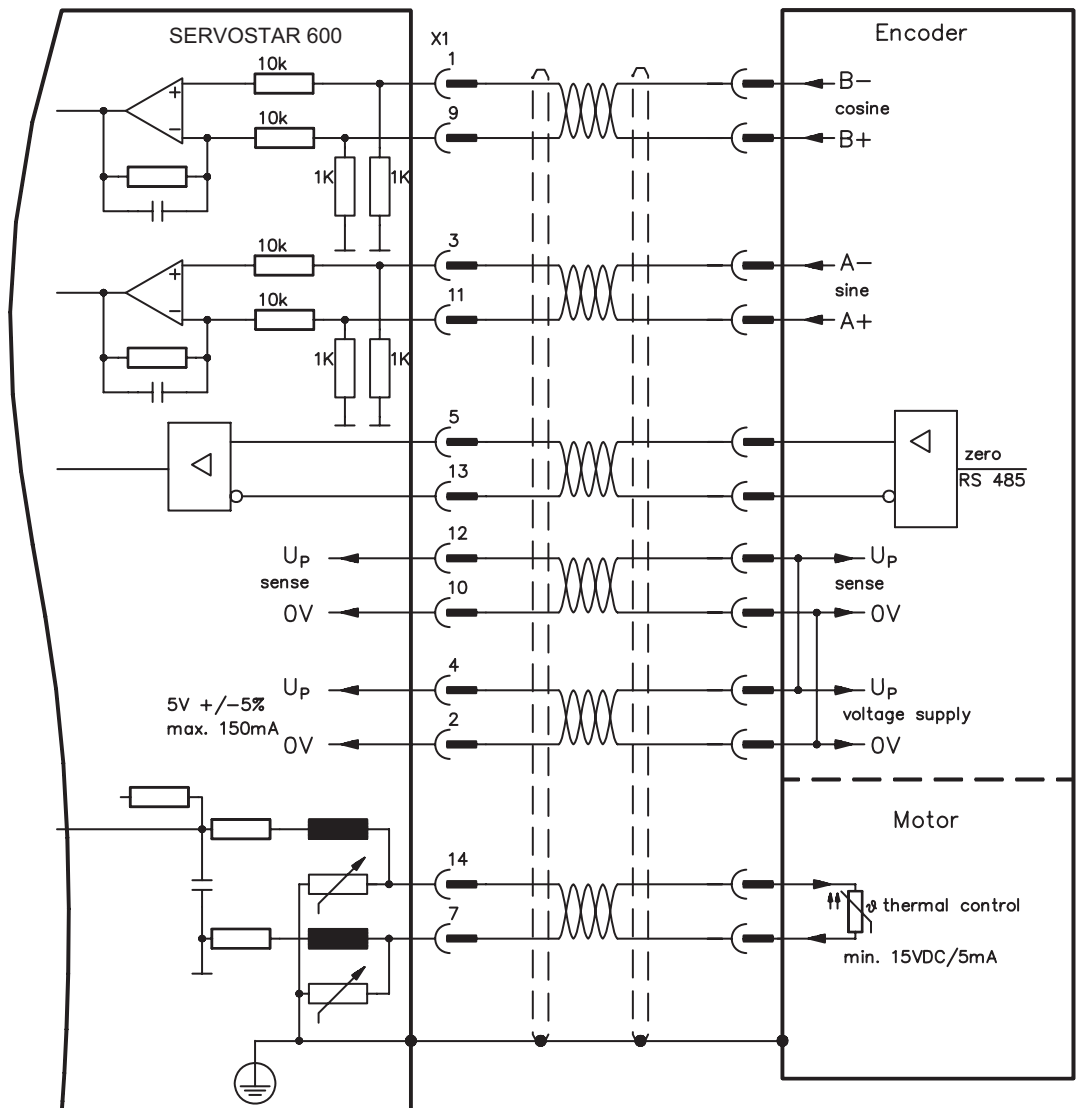

8.11.5 Incremental encoder / sine encoder with Hall (X1)

Encoder types (incremental or sine/cosine) that do not provide definitive information on commutation, can be used as a complete feedback system using an additional Hall dongle. In this case, an adapter is used for interfacing and adapting the signals (Hall dongle, ⇒ p. 90). This adapter is also used to connect encoders known as ComCoders.

Encoder types with a power consumption of more than 150mA can also be connected using our external power supply (⇒ p. 113). For encoders that do not have integrated terminating resistors, we offer an optional terminating adapter (⇒ p. 113)

If you plan to use a cable longer than 25m, please contact our application department.

Frequency limit (A, B): 250 kHz
 RS422 with Hall: FBTYPE 12
 Encoder with Hall: FBTYPE 11

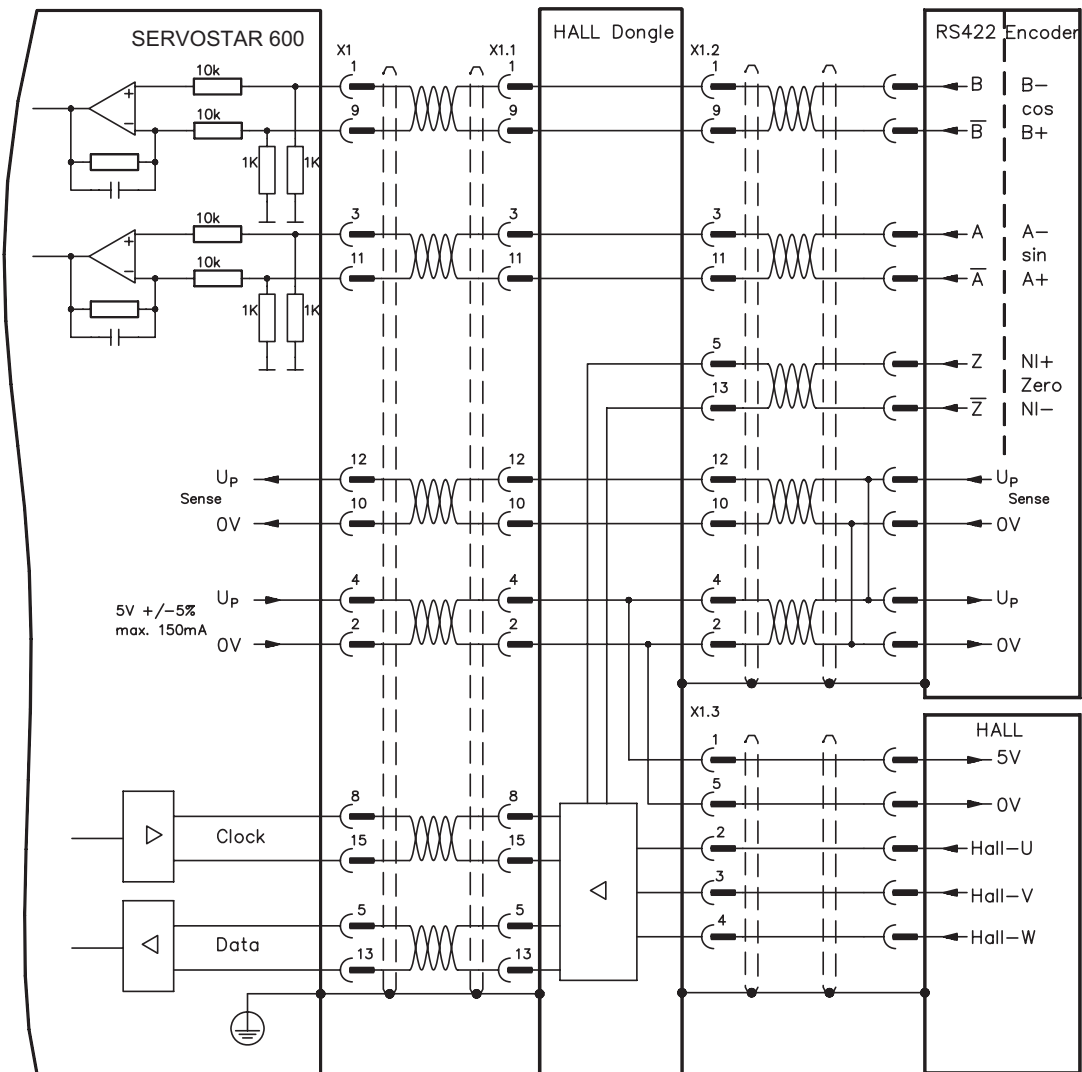

8.11.6 Incremental Encoder (X5)

An incremental encoder can be used as standard motor feedback.

Every time the 24V auxiliary voltage is switched on, the amplifier needs start-up information for the position controller (parameter value MPHASE). Depending on the feedback type either wake&shake is executed or the value for MPHASE is read out of the amplifier's EEPROM.

The thermal control in the motor is connected to X1 (see p.54) or X2 (see p.52).

If lead lengths of more than 50m are planned and for questions concerning the power supply of the encoder, please consult our customer service.

NOTE

AGND and DGND (connector X3) must be joined together !

Frequency limit: 1.5 MHz

Encoder type	FCTYPE	Remarks
RS422 5V	9	MPHASE from EEPROM
RS422 5V	8	MPHASE with wake & shake

WARNING

With vertical load the load could fall during wake&shake, because the brake is not active and torque is not sufficient to hold the load. Don't use this feedback type with vertical load (hanging load).

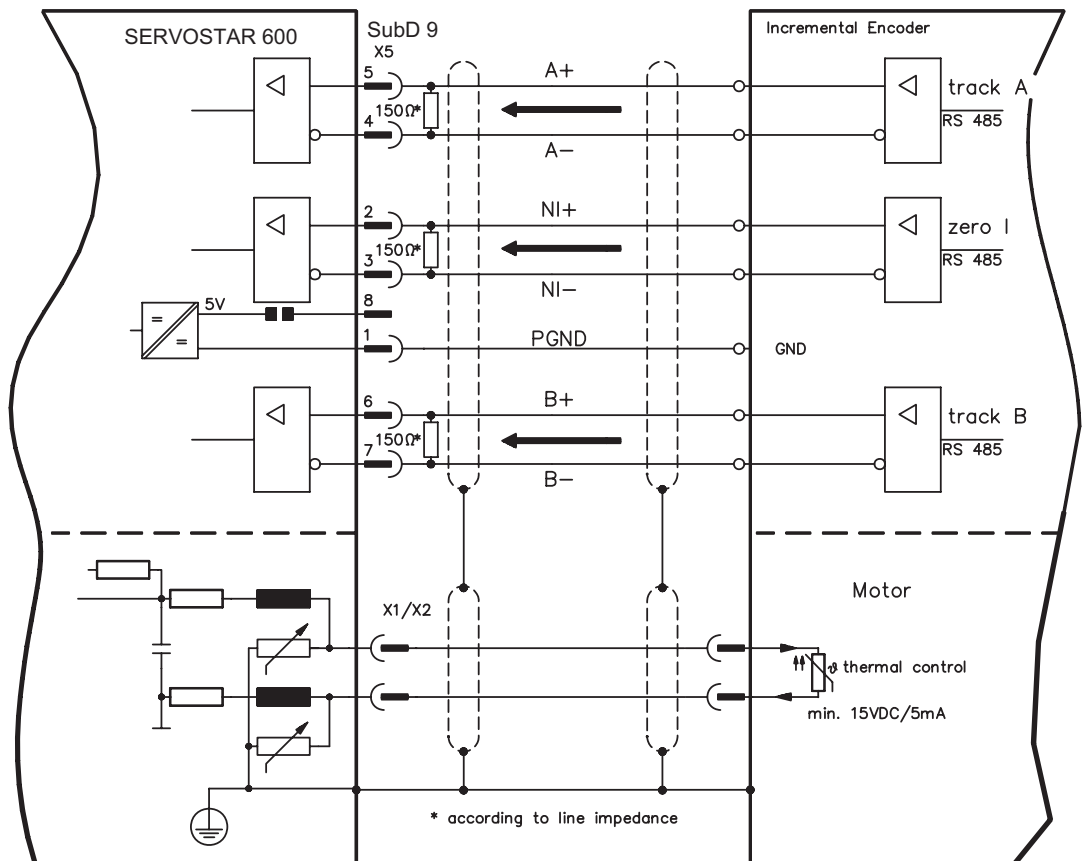

8.12 Electronic Gearing, Master-slave operation

In the case of the “electronic gearing” functionality (see setup software and description of GEARMODE parameter), the servo amplifier is controlled by a secondary feedback device as a slave.

It is possible to set up master/slave systems, use an external encoder as a setpoint encoder or connect the amplifier to a stepper motor control.

The amplifier is parameterized using the setup software (electronic gearing).

Primary Feedback: adjust on screen page "Feedback" (FBTYPE)

Secondary Feedback: adjust on screen pages "Position" and "Gearing" (EXTPOS, GEARMODE)

Master-/Slave adjustment

Master: adjust encoder emulation on screen page "ROD/SSI/Encoder" (ENCMODE)

Slave: adjust on screen pages "Position" and "Gearing" (EXTPOS, GEARMODE)

The following types of external encoder can be used:

secondary Feedback type	Connector	Wiring diagram	GEARMODE
Incremental Encoder 5V	X5	⇒ p.59	3, 5*, 13*, 15*
Incremental Encoder 24V	X3	⇒ p.59	0, 2*, 10*, 12*
Sine/Cosine Encoder	X1	⇒ p.60	6, 8*, 9*, 16*
SSI Encoder	X5	⇒ p.61	7*, 17*
Pulse and Direction 5V	X5	⇒ p.62	4, 14*
Pulse and Direction 24V	X3	⇒ p.62	1, 11*

* adjustable via terminal screen of the setup software

The following table shows the allowed feedback combinations:

Primary Feedback	Secondary Feedback for Position control/Following			
	Sine Encoder (X1)	Increment. Encoder 5V/24V (X5/X3)	Pulse&Direct. 5V/24V (X5/X3)	SSI Encoder (X5)
Resolver (X2) FBTYPE = 0	EXTPOS = 1,2,3 GEARMODE = 6,8,9,16 FPGA = 0 ENCMODE = 0	EXTPOS = 1,2,3 GEARMODE = 0,2,3,5,10,12,13,15 FPGA = 0 ENCMODE = 0	EXTPOS = 1,2,3 GEARMODE = 1,4,11,14 FPGA = 0 ENCMODE = 0	EXTPOS = 1,2,3 GEARMODE = 7,17 FPGA = 1 ENCMODE = 2
Sine Encoder (X1) FBTYPE = 2,4,6,7,20	-	EXTPOS = 1,2,3 GEARMODE = 0,2,3,5,10,12,13,15 FPGA = 1 ENCMODE = 0	EXTPOS = 1,2,3 GEARMODE = 1,4,11,14 FPGA = 1 ENCMODE = 0	EXTPOS = 1,2,3 GEARMODE = 7,17 FPGA = 1 ENCMODE = 2
Encoder & Hall (X1) FBTYPE = 11,12	-	EXTPOS = 1,2,3 GEARMODE = 0,2,3,5,10,12,13,15 FPGA = 1 ENCMODE = 0	EXTPOS = 1,2,3 GEARMODE = 1,4,11,14 FPGA = 1 ENCMODE = 0	-
RS422 Encoder (X5) FBTYPE = 8,9	-	-	-	-
Sensorless FBTYPE = 10	-	EXTPOS = 1,2,3 GEARMODE = 0,2,3,5,10,12,13,15 FPGA = 0 ENCMODE = 0	EXTPOS = 1,2,3 GEARMODE = 1,4,11,14 FPGA = 0 ENCMODE = 0	EXTPOS = 1,2,3 GEARMODE = 7,17 FPGA = 1 ENCMODE = 2

8.12.1 Connection to a SERVOSTAR master, 5 V signal level (X5)

You can link several SERVOSTAR amplifiers together in master-slave operation.

Up to 16 slave amplifiers can be controlled by the master via the encoder output. The connector X5 must be used.

Frequency limit: 1,5 MHz, slew rate $t_v \leq 0,1 \mu s$

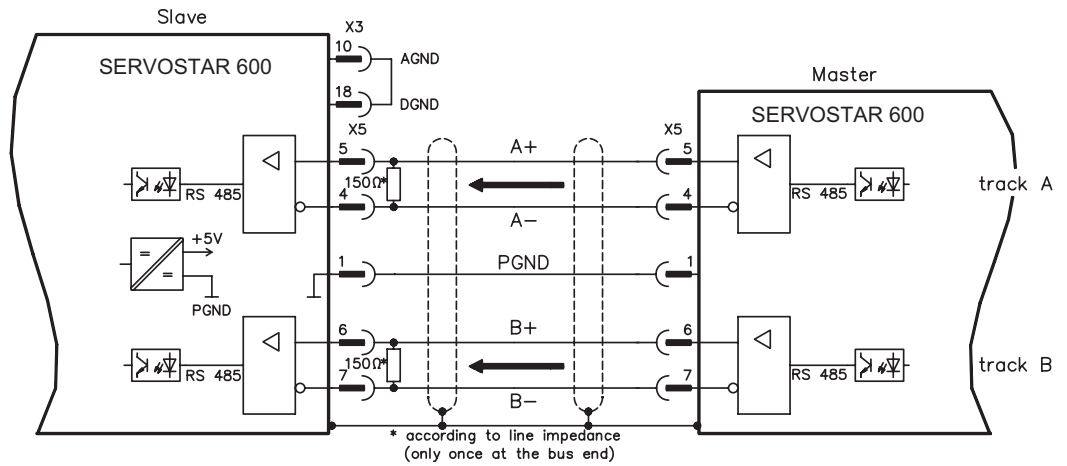

NOTE AGND and DGND (connector X3) must be joined together !

8.12.2 Connection to encoders with 24 V signal level (X3)

This interface can be used to operate the SERVOSTAR as a slave, mastered by an encoder with 24 V signal level (master-slave operation). The digital inputs DIGITAL-IN 1 and 2 at connector X3 must be used. Frequency limit: 250 kHz, slew rate $t_v \leq 0,1 \mu s$

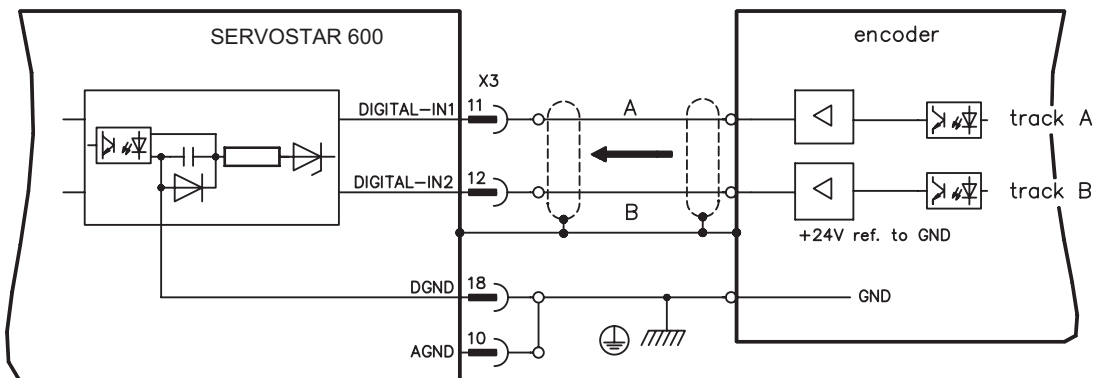

NOTE AGND and DGND (connector X3) must be joined together !

8.12.3 Connection to a sine-cosine encoder (X1)

You can operate the SERVOSTAR as a slave, mastered by a sine-cosine encoder (master-slave operation). The connector X1 must be used.

Encoder types with a power consumption of more than 150 mA can also be connected using our external power supply (⇒ p.113). For encoders that do not have integrated terminating resistors, we offer an optional terminating adapter (⇒ p. 113).

Frequency limit: 250 kHz

NOTE AGND and DGND (connector X3) must be joined together !

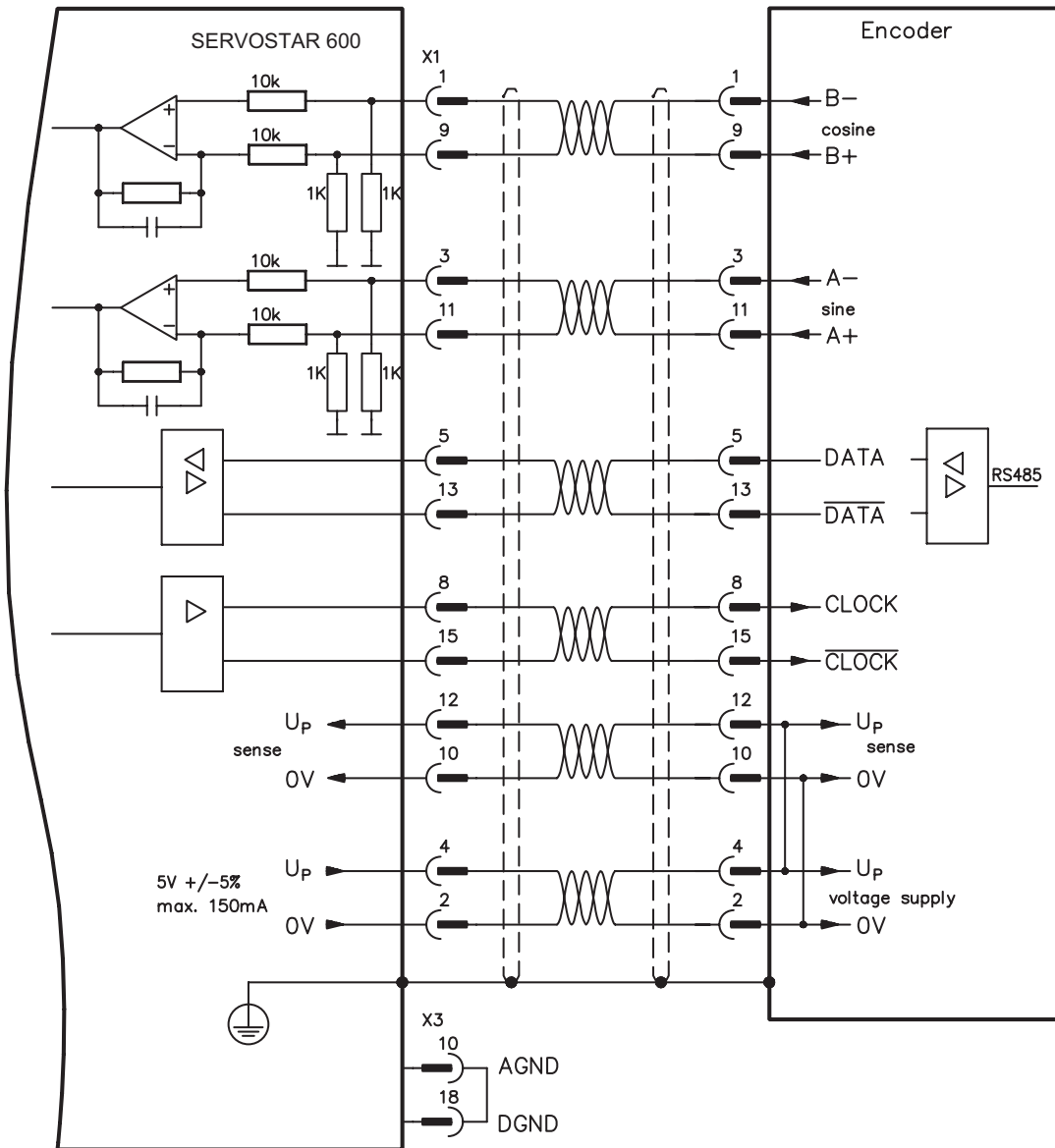

8.12.4 Connection to an SSI encoder (X5)

You can set up the SERVOSTAR 600 as a slave following a synchronous serial absolute-encoder (master-slave operation). This application uses the SubD connector X5. If lead lengths of more than 50 m are planned and for questions concerning the power supply of the encoder, please consult our customer service.

Frequency limit: 1,5MHz

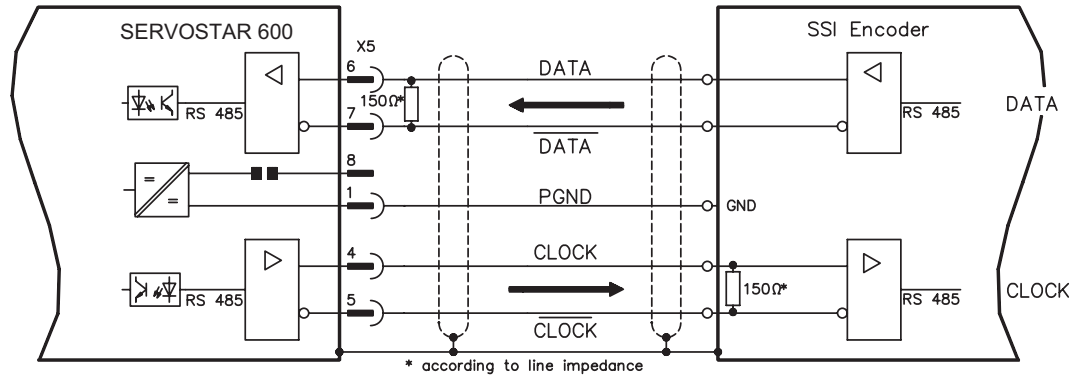

NOTE AGND and DGND (connector X3) must be joined together!

8.12.5 Connection to stepper motor controllers (step and direction)

This interface can be used to connect the servo amplifier to a third-party stepper-motor controller. The parameters for the servo amplifier are set up with the aid of the setup software (electrical gearing). The number of steps can be adjusted, so that the servo amplifier can be adjusted to the pulse-direction signals of any stepper-motor controller. Various monitoring signals can be output. The analog setpoint inputs are out of action.

NOTE Observe the frequency limit!
Using an A quad B encoder provides better EMC noise immunity.

Speed profile and signal diagram

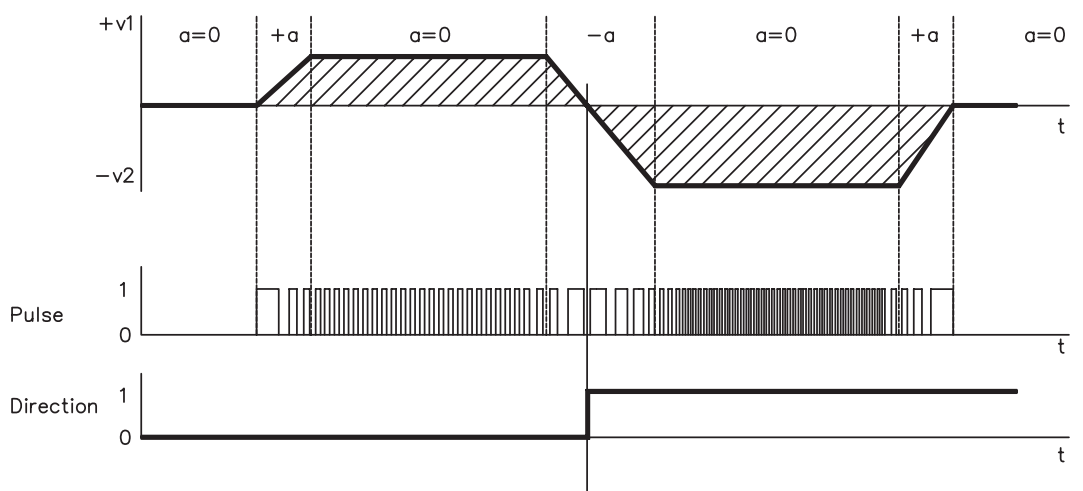

Equivalences
 path traversed s — number of pulses
 velocity v — pulse frequency
 acceleration a — rate of change of pulse frequency

8.12.5.1 Step/Direction with 5 V signal level (X5)

Connection of the servo amplifier to a stepper-motor controller with 5 V signal level. The connector X5 must be used.
 Frequency limit: 1,5 MHz

NOTE AGND and DGND (connector X3) must be joined together !

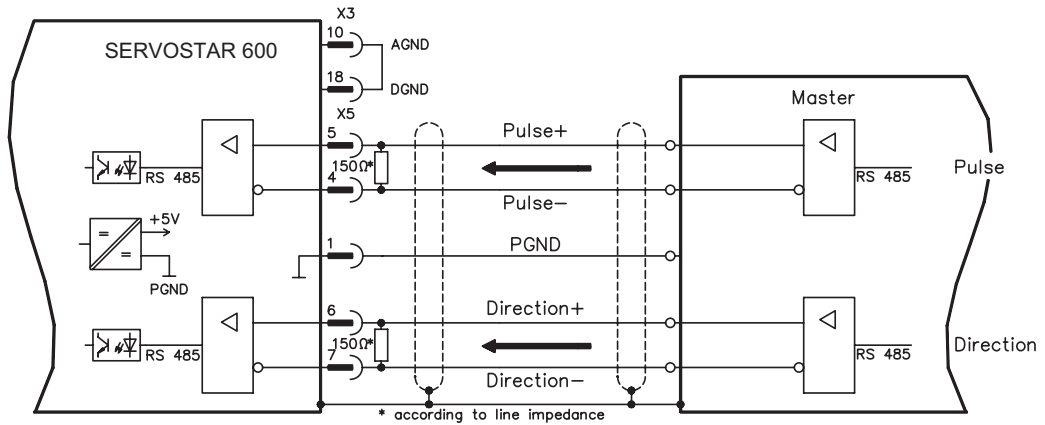

8.12.5.2 Step/Direction with 24 V signal level (X3)

Connection of a servo amplifier to a stepper-motor controller with 24 V signal level. The digital inputs DIGITAL-IN 1 and 2 at connector X3 must be used.
 Frequency limit: 250 kHz

NOTE AGND and DGND (connector X3) must be joined together !

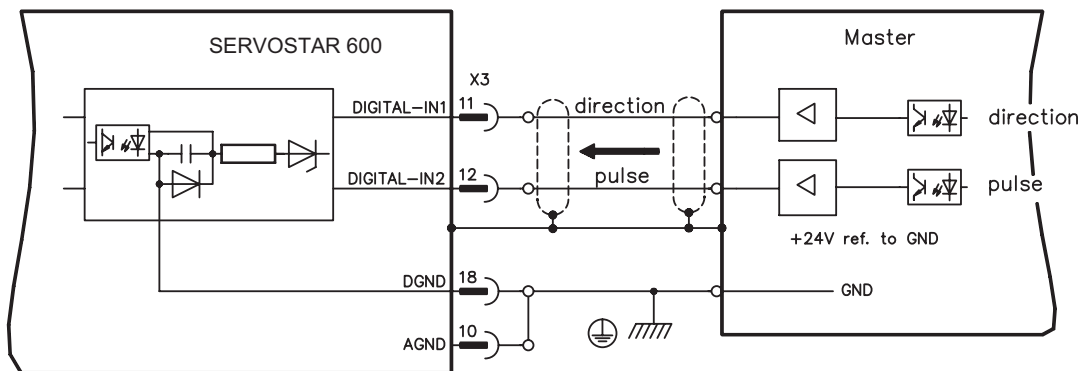

8.13 Encoder emulations

8.13.1 Incremental encoder output - A quad B (X5)

The incremental-encoder interface is part of the package supplied. Select the encoder function ROD (screen page "Encoder"). In the servo amplifier, the position of the motor shaft is calculated from the cyclic-absolute signals of the resolver or encoder. Incremental-encoder compatible pulses are generated from this information. Pulses are output on the SubD-connector X5 as two signals, A and B, with 90° phase difference and a zero pulse.

The resolution (lines before quadrature) can be changed with the RESOLUTION parameter:

Encoder function (ENCMODE)	Feedback system	Resolution	Zero position
ROD (1)	Resolver	256...4096	one per revolution (only if A=B=1)
	Encoder	256...524288 ($2^8 \dots 2^{19}$)	one per revolution (only if A=B=1)
ROD interpolation (3)	Encoder	$2^2 \dots 2^7$ TTL lines per sine line	analog pass through from X1 to X5

You can also adjust and store the position of the zero pulse within one mechanical turn (parameter NI-OFFSET).

NOTE The drivers are supplied from an internal supply voltage. PGND must always be connected to the controls. The max. admissible cable length is 10 m.

Connections and signal description for incremental-encoder interface :

Default count direction: upwards when the motor shaft is rotating clockwise (looking at the shaft end).

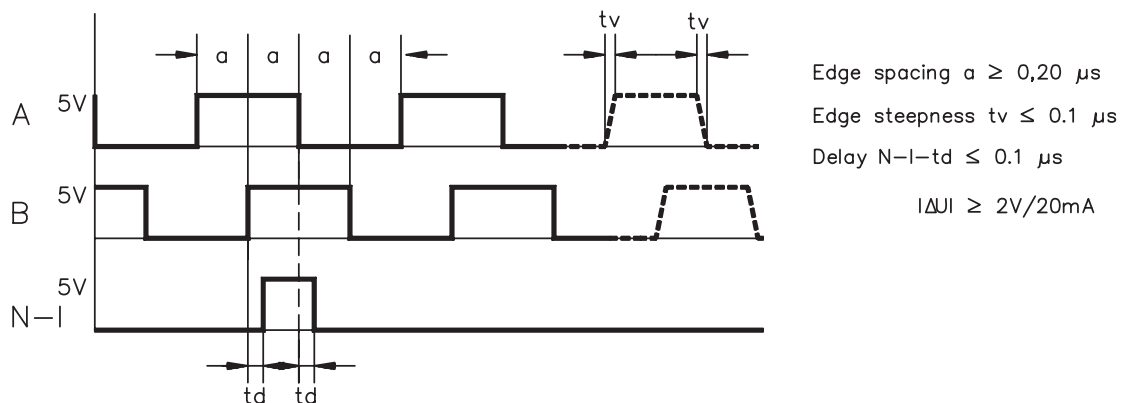
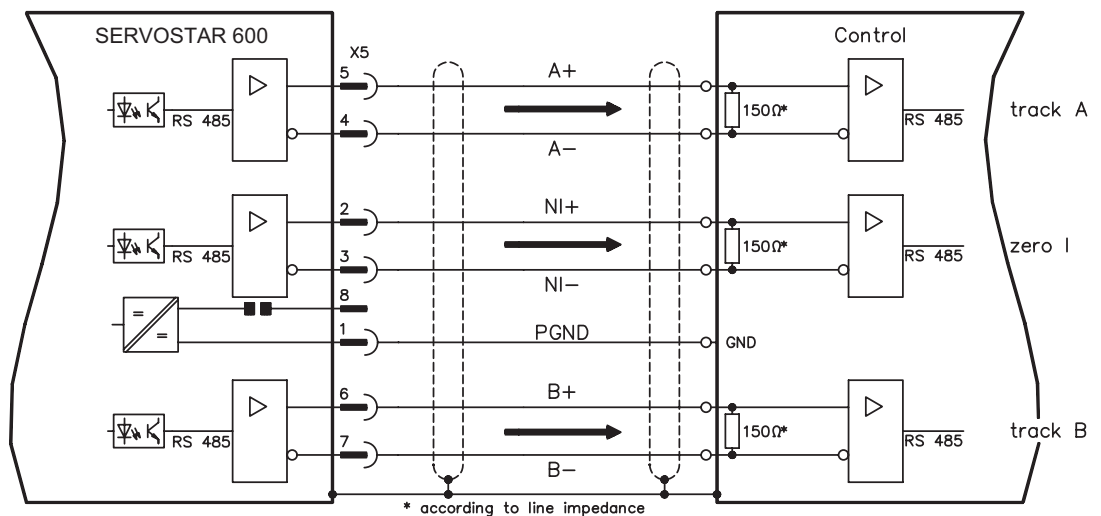

8.13.2 SSI output (X5)

The SSI interface (synchronous serial absolute-encoder simulation) is part of the delivered package. Select the encoder function SSI (screen page "Encoder"). In the servo amplifier, the position of the motor shaft is calculated from the cyclically absolute signals from the resolver or encoder. This information is used to create a position output in a format that is compatible with the standard SSI-absolute-encoder format. 24 bits are transmitted.

SINGLE TURN selected: The upper 12 bits are fixed to ZERO, the lower 12 bits contain the position information. For 2-pole resolvers, the position value refers to the position within one turn of the motor, for 4-pole resolvers it is within half a turn, and for 6-pole resolvers it is within a third of a turn. Exception: If an encoder with a commutation track is used as the feedback unit, then the upper 12 bits are set to 1 (data invalid!) until a homing run is performed.

MULTI TURN selected: The upper 12 bits contain the number of motor turns, the lower 12 bits contain the position information.

The signal sequence can be output in **Gray** code (standard) or in **binary** code (parameter SSI-CODE). The servo amplifier can be adjusted to the clock frequency of your SSI-evaluation with the SSI-TAKT parameter (200 kHz or 1.5MHz and inverted).

NOTE Drivers are supplied from internal supply voltage. PGND must always be connected.

Connection and signal description for SSI interface :

Default count direction: upwards when the motor shaft is rotating clockwise (looking at the shaft end).

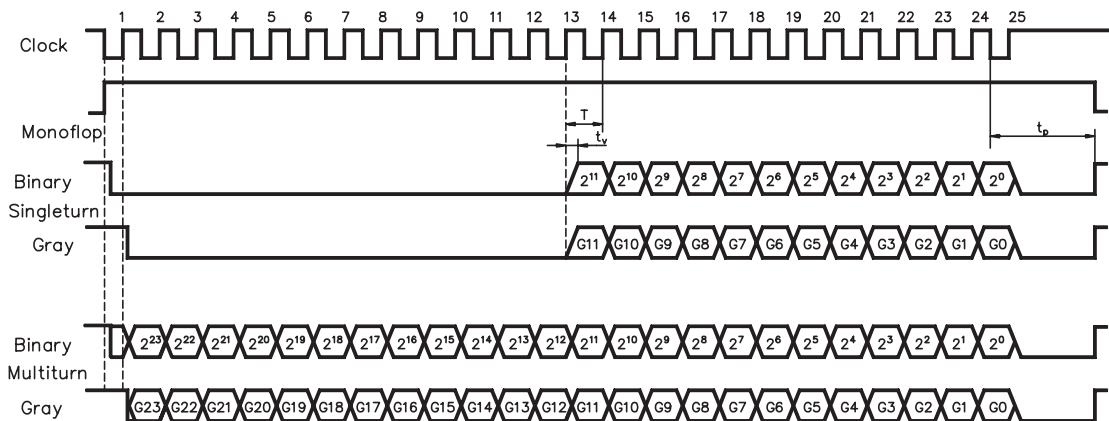
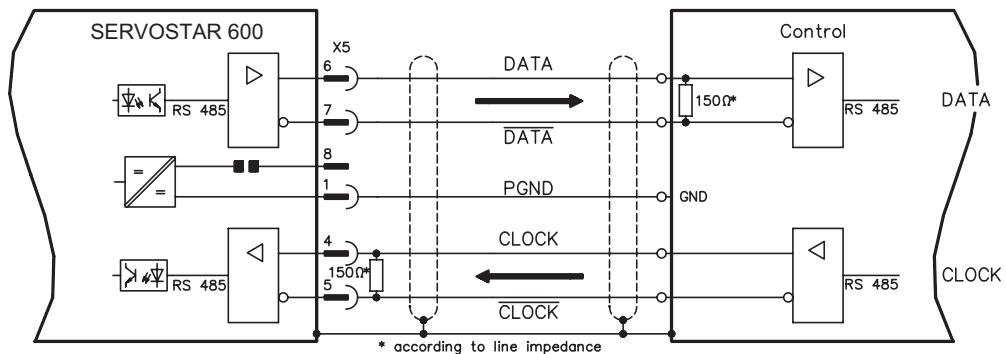

Transfer bit rate	Monoflop stabilize time
200 KBaud	$t_p \approx 13\mu s$
1,5 MBaud	$t_p \approx 3\mu s$

Switch over time Data $t_v \leq 300nsec$
 Period $T = 600 ns$
 Output $I_{\Delta U} \geq 2V/20mA$
 Input $I_{\Delta U} \geq 0,3V$

8.14 Digital and analog inputs and outputs

8.14.1 Analog inputs (X3)

The servo amplifier is equipped with two differential inputs for analog setpoints which are **programmable**. AGND (X3/1) must always be joined to the CNC-GND of the controls as a ground reference.

Technical characteristics

- Differential-input voltage max. ± 10 V
- Resolution 1.25 mV
- Ground reference AGND, terminal X3/1
- Input resistance 20 k Ω
- Common-mode voltage range for both inputs ± 10 V
- Update rate 62.5 μ s

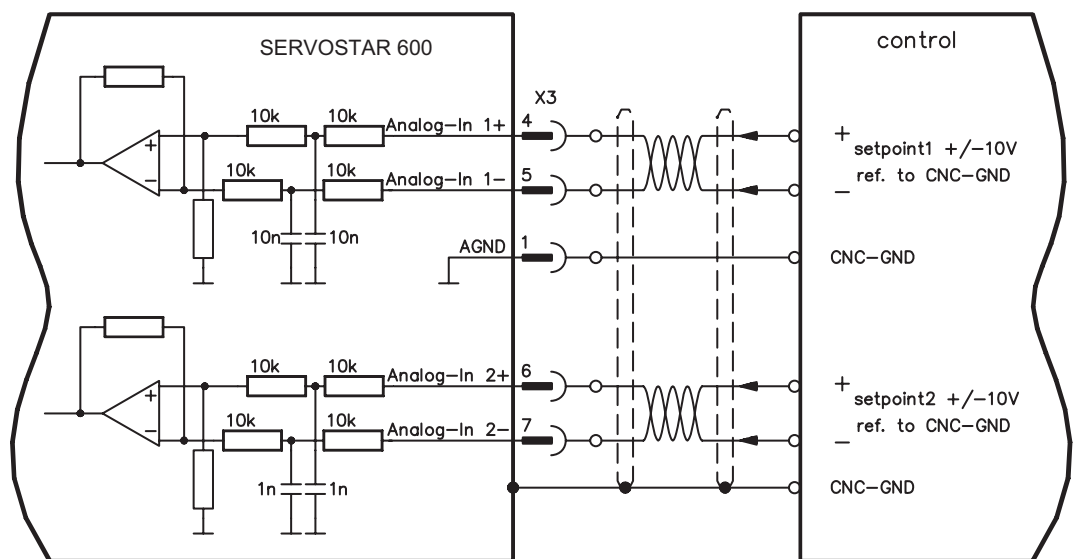

Input Analog-In 1 (terminals X3/4-5)

Differential input voltage max. ± 10 V, resolution 14-bit, scalable
Standard setting : speed setpoint

Input Analog-In 2 (terminals X3/6-7)

Differential input voltage max. ± 10 V, resolution 12-bit, scalable
Standard setting : torque setpoint

Application examples for setpoint input Analog-In 2:

- adjustable external current limit
- reduced-sensitivity input for setting-up/jog operation
- pre-control / override

Fixing the direction of rotation

Standard setting : clockwise rotation of the motor shaft (looking at the shaft end)

- Positive voltage between terminal X3/4 (+) and terminal X3/5 (-) or
- Positive voltage between terminal X3/6 (+) and terminal X3/7 (-)

To reverse the direction of rotation, swap the connections to terminals X3/4-5 and X3/6-7 or change the ROT. DIRECTION parameter in the "Speed controller" screen.

8.14.2 Analog outputs (X3)

Technical characteristics

- Reference ground is analog-GND (AGND, terminal X3/1 and X3/10)
- Output resistance 2.2 k Ω
- Output voltage ± 10 V
- Resolution 10 bit.
- Update rate 62.5 μ s

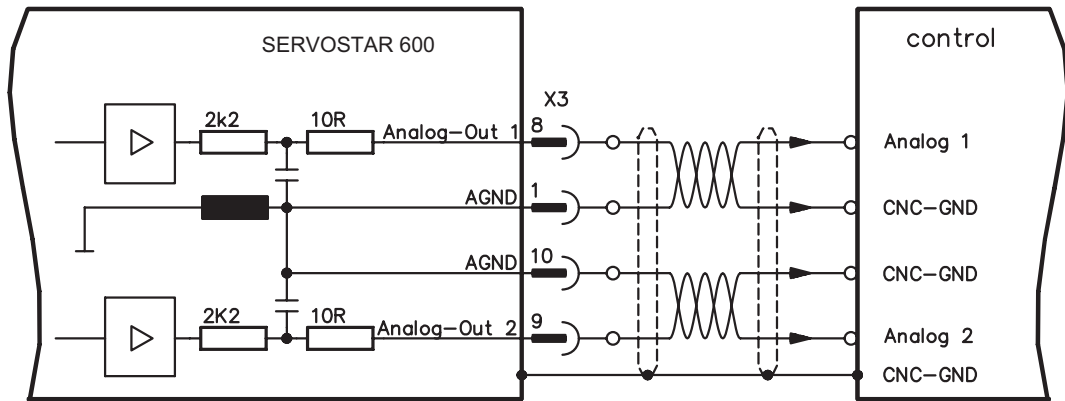

Programmable analog outputs Analog-Out 1 / Analog-Out 2

The terminals X3/8 (Analog-Out 1) or X3/9 (Analog-Out 2) can have the following analog signals assigned to them:

Standard setting :

Analog-Out 1 : Tachometer voltage n_{act} (speed)

The output delivers ± 10 V at the preset limit speed.

Analog-Out 2 : Current actual value I_{act} (torque)

The output delivers ± 10 V at the preset peak current I_{peak} (effective r.m.s. value).

You can use the terminals X3/8 (Analog-Out 1) or X3/9 (Analog-Out 2) to output converted analog values for digital measurements which are contained in the servo amplifier.

You can find a list of pre-programmed functions on the "Analog I/O" screen of our setup software.

8.14.3 Digital inputs (X3)

All digital inputs are **electrically isolated** through optocouplers.

Technical characteristics

- Reference ground is **digital-GND** (DGND, terminal X3/18)
- Inputs at X3 meet PLC standards (IEC 61131-2 Type 1)
- High: 11...30V / 2...11mA, Low -3...+5V / <1 mA
- Update rate: 250µs

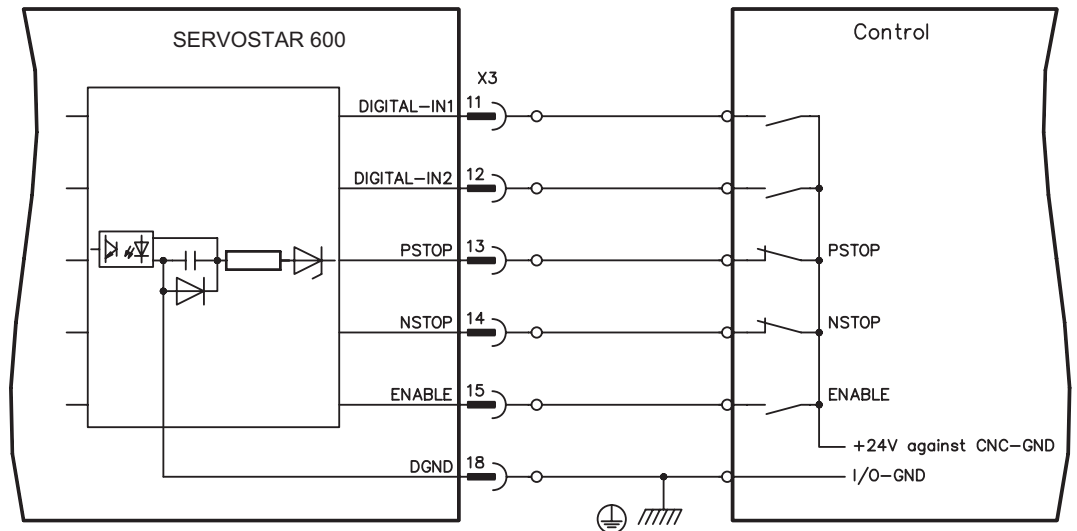

ENABLE input

The output stage of the servo amplifier is activated by the enable signal (terminal X3/15, input 24V, **active-high**).

In the inhibited state (low signal) the motor which is attached does not have any torque.

Programmable digital inputs :

You can use the digital inputs PSTOP / NSTOP / DIGITAL-IN1 and DIGITAL-IN2 to initiate preprogrammed functions that are stored in the servo amplifier.

You can find a list of pre-programmed functions on the "digital I/O" screen of our setup software.

If an input is freshly assigned to a pre-programmed function, then the data set must be stored in the EEPROM of the servo amplifier, and the 24V auxiliary supply of the servo amplifier must be switched off and on again (to reset the amplifier software).

Limit-switches PSTOP / NSTOP

Terminals X3/13 and X3/14 are normally programmed for the connection of limit switches. If these inputs are not needed for the connection of limit switches, then they are programmable for other input functions.

Limit-switch positive/negative (**PSTOP / NSTOP**, terminals X3/13 and X3/14), high level in normal operation (fail-safe for a cable break).

A low signal (open) inhibits the corresponding direction of rotation, **the ramp function remains effective**.

DIGITAL-IN 1 / DIGITAL-IN 2

The digital inputs on terminal X3/11 (DIGITAL-IN 1) or terminal X3/12 (DIGITAL-IN 2) can be logically combined in a pre-programmed function.

8.14.4 Digital outputs (X3)

Technical characteristics

- Reference ground is digital-GND (DGND, terminal X3/18)
- All digital outputs are floating
- DIGITAL-OUT1 and 2 : Open-Collector, max. 30 VDC, 10 mA
- BTB/RTO : Relay output, max. 30 VDC or 42 VAC, 0.5 A
- Update rate : 250 μ s

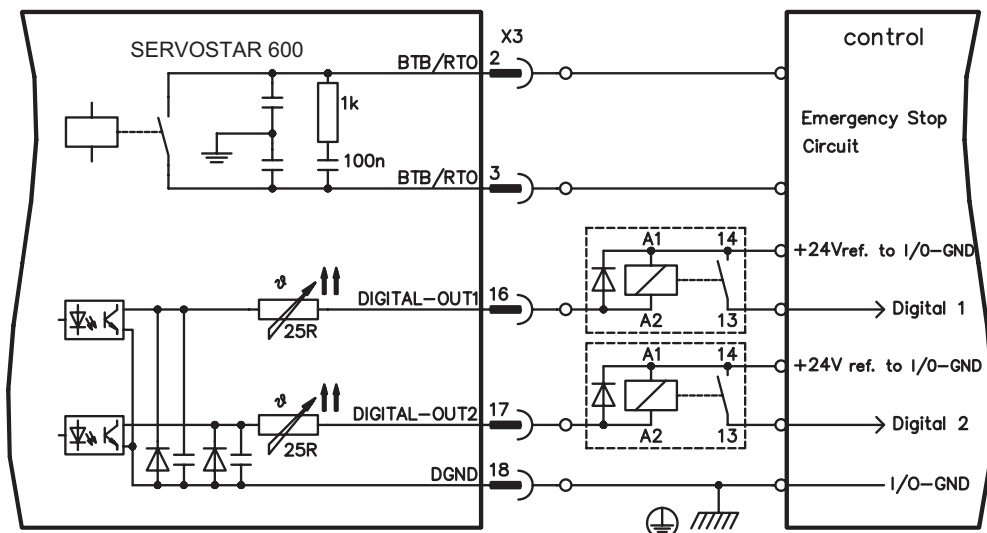

Ready-to-operate contact BTB/RTO

Operational readiness (terminals X3/2 and X3/3) is signaled by a **floating** relay contact. The contact is **closed** when the servo amplifier is ready for operation, the signal is **not** influenced by the enable signal, the I²t-limit, or the brake threshold.

NOTE

All faults cause the BTB/RTO contact to open and the switch-off of the output stage (if the BTB contact is open, the output stage is disabled -> no power). A list of the error messages can be found on page 88.

Programmable digital outputs DIGITAL-OUT 1 / 2:

You can use the digital outputs DIGITAL-OUT1 (terminal X3/16) and DIGITAL-OUT2 (terminal X3/17) to output messages from pre-programmed functions that are stored in the servo amplifier. You can find a list of pre-programmed functions on the "digital I/O" screen of our setup software.

If an input is freshly assigned to a pre-programmed function, then the data set must be stored in the EEPROM of the servo amplifier, and the 24V auxiliary supply of the servo amplifier must be switched off and on again (to reset the amplifier software).

Evaluate the outputs via inverting interface relays (see connection diagram), for example Phoenix DEK-REL-24//1 (turn-on delay 6 ms, turn-off delay 16ms).

NOTE

The described logic in the [online help](#) of the setup software refers to the output of the inverting interface relays. Consider the delay of the applied relay !

8.15 RS232 interface, PC connection (X6)

The setting of the operating, position control, and motion-block parameters can be carried out with an ordinary commercial PC.

Connect the PC interface (X6) of the servo amplifier **while the supply to the equipment is switched off** via a normal commercial 3-core null-modem cable to a serial interface on the PC.

NOTE

Do not use a null-modem link cable!

The interface is electrically isolated through an optocoupler, and is at the same potential as the CANopen interface.

The interface is selected and set up in the setup software.
Further notes can be found on page 72.

With the optional expansion card -2CAN- the two interfaces for RS232 and CAN, which otherwise use the same connector X6, are separated onto two connectors (⇒ p.111).

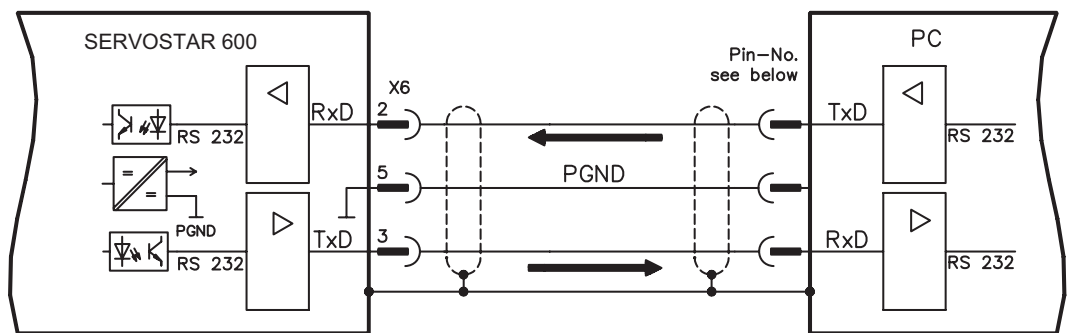

Interface cable between the PC and servo amplifiers of the SERVOSTAR 600 series:

(View : looking at the face of the built-in SubD connectors, this corresponds to the solder side of the SubD sockets on the cable)

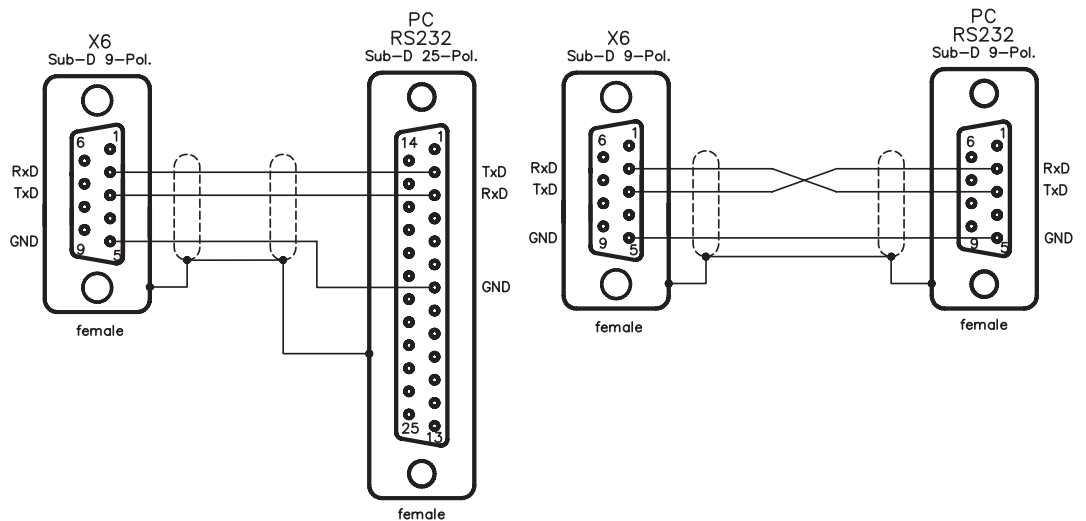

8.16 CANopen Interface (X6)

The interface for connection to the CAN bus (default 500 kBaud). The integrated profile is based on the communication profile CANopen DS301 and the drive profile DS402. The following functions are available in connection with the integrated position controller:

Jogging with variable speed, reference traverse (zeroing), start motion task, start direct task, digital setpoint provision, data transmission functions and many others.

Detailed information can be found in the CANopen manual. The interface is electrically isolated by optocouplers, and is at the same potential as the RS232 interface. The analog setpoint inputs can still be used.

With the optional expansion card -2CAN- the two interfaces for RS232 and CAN, which otherwise use the same connector X6, are separated onto two connectors ⇒ p.111).

NOTE AGND and DGND (connector X3) must be joined together !

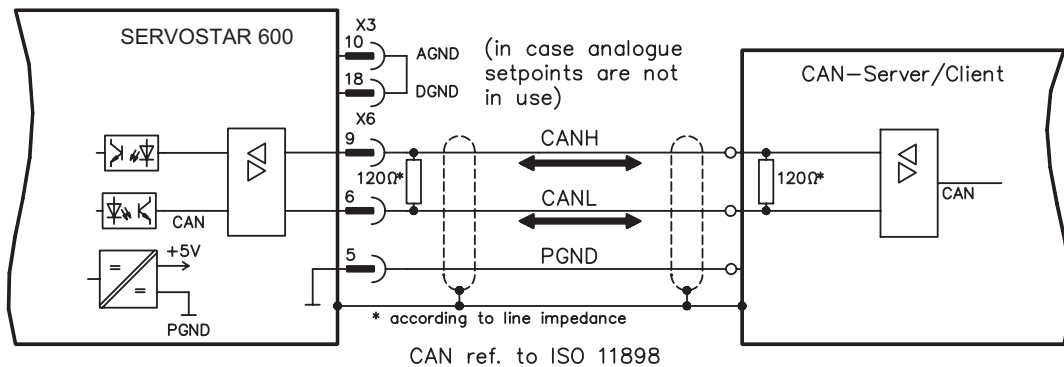

CAN bus cable

To meet ISO 11898 you should use a bus cable with a characteristic impedance of 120 Ω. The maximum usable cable length for reliable communication decreases with increasing transmission speed. As a guide, you can use the following values which we have measured, but they are not to be taken as assured limits:

Cable data:	Characteristic impedance	100-120 Ω
	Cable capacitance	max. 60 nF/km
	Lead resistance (loop)	159.8 Ω/km

Cable length, depending on the transmission rate

Transmission rate (kbaud)	max. cable length (m)
1000	20
500	70
250	115

Lower cable capacitance (max. 30 nF/km) and lower lead resistance (loop, 115 Ω/km) make it possible to achieve greater distances.

(Characteristic impedance 150 ± 5Ω ⇒ terminating resistor 150 ± 5Ω).

For EMC reasons, the SubD connector housing must fulfill the following conditions:

- metal or metallised housing
- provision for cable shielding connection in housing, large-area connection

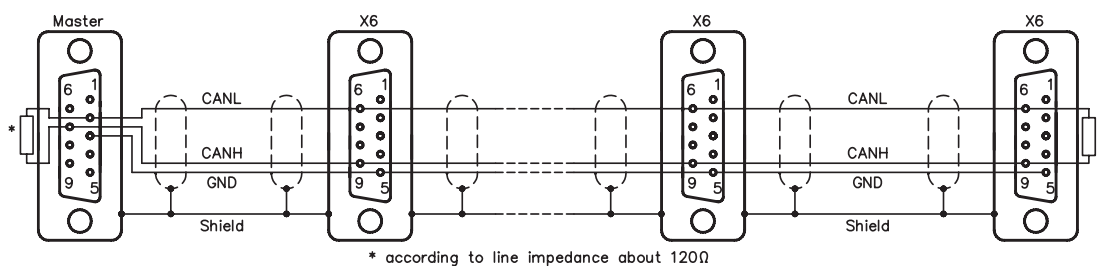

9 Setup

The procedure for setup is described as an example. Depending on the application, a different procedure may be sensible or necessary. In multi-axis systems, setup each servo amplifier individually.

9.1 Safety Instructions

⚠ DANGER Check that all live connecting elements are protected from accidental contact. Deadly voltages can be present, up to 900V.

⚠ WARNING Never disconnect any of the electrical connections to the servo amplifier while it is live. Capacitors can still have residual charges with dangerous levels up to 300 seconds after switching off the supply power.

⚠ CAUTION Heat sinks and front panels of the amplifier can reach a temperature of up to 80°C(176°F) in operation. Check (measure) the heat sink temperature. Wait until the heat sink has cooled down below 40°C (104°F) before touching it.

⚠ CAUTION The manufacturer of the machine must generate a hazard analysis for the machine, and take appropriate measures to ensure that unforeseen movements cannot cause injury or damage to any person or property.

⚠ CAUTION Only professional personnel with extensive knowledge in the fields of electrical/ drive technology are allowed to setup the servo amplifier.

NOTE If the servo amplifier has been stored for longer than 1 year, then the DC bus link capacitors will have to be re-formed.
To do this, disconnect all the electrical connections.
Supply the servo amplifier for about 30 min. from single-phase 230VAC to the terminals L1 / L2. This will re-form the capacitors.

NOTE Further information on setup :
The adaptation of parameters and the effects on the control loop behavior are described in the [online help](#) of the setup software.
The setup of the expansion card (if present) is described in the corresponding manual on the CD-ROM.
We can provide further know-how through training courses (on request).

9.2 Setup software

9.2.1 General

This chapter describes the installation of the setup software DRIVE.EXE for the SERVOSTAR 600 digital servo amplifiers.

We offer training and familiarization courses on request.

9.2.1.1 Use as directed

The setup software is intended to be used for setting up and storing the operating parameters for the SERVOSTAR 600 series of servo amplifiers. The attached servo amplifier can be setup with the assistance of the software - during this process the drive can be controlled directly by the service functions.

**WARNING**

Only professional personnel who have the relevant expertise described on page 7 are permitted to carry out online parameter setting for a drive which is running. Sets of data which are stored on data media are not safe against unintended alteration by other persons. After loading a set of data you must therefore check all parameters thoroughly before enabling the servo amplifier.

9.2.1.2 Software description

The servo amplifiers must be adapted to the requirements of your installation. Usually you will not have to carry out this parameter setting yourself on the amplifier, but on a PC, with the assistance of the setup software. The PC is connected to the servo amplifier by a null-modem cable (see p.69) . The setup software provides the communication between SERVOSTAR 600 and the PC.

You will find the setup software on the accompanying CD-ROM and at our web site.

With very little effort you can alter parameters and instantly observe the effect on the drive, since there is a continuous (online) connection to the amplifier.

Simultaneously, important actual values are read out from the amplifier and displayed on the PC monitor (oscilloscope function).

Any interface modules (expansion cards) which may be built into the amplifier are automatically recognized, and the additional parameters which are required for position control or motion-block definition are made available.

Sets of data can be stored on data media (archived) and loaded again. Sets of data which are stored on data media can be printed.

We supply you with motor-specific default sets of data for the most common combinations of servo amplifier and motor. In most applications you will be able to use these default values to get your drive running without any problems.

An extensive [online help](#) with integrated description of all variables and functions supports you in each situation.

9.2.1.3 Hardware requirements

The PC interface (X6, RS232) of the servo amplifier is connected to the serial interface of the PC by a null-modem cable (**not a null-modem link cable !**) (⇒ p.69).



WARNING Connect / disconnect the interface cable only when the supply is switched off for both the PC and the servo amplifier.

The interface in the servo amplifier is electrically isolated by an optocoupler, and is at the same potential as the CANopen interface.

Minimum requirements for the PC:

Processor	:	Pentium® I or higher
Operating system	:	WINDOWS 95(c) / 98 / 2000 / ME / NT 4.0 / XP
Graphics adapter	:	Windows compatible, color
Drives	:	hard disk with at least 10 MB free space CD-ROM drive
Main memory	:	at least 8MB
Interface	:	one free serial interface (COM1...COM10)

9.2.1.4 Operating systems

WINDOWS 95(c) / 98 / 2000 / ME / NT / XP

DRIVE.EXE is executable under WINDOWS 95(c) / 98 / 2000 / ME / XP and WINDOWS NT 4.0. The HTML help system is **not** available under WINDOWS 95a and 95b. In emergency, operation is possible through an ASCII terminal emulation (without user-interface). Interface settings : 9600 bps, no parity, no handshake.

WINDOWS FOR WORKGROUPS 3.xx, DOS, OS2 Unix, Linux

DRIVE.EXE is **not** executable under WINDOWS 3.xx, DOS, OS2, Unix and Linux.

WINDOWS VISTA, WINDOWS 7

DRIVE.EXE is **not** tested with WINDOWS VISTA and WINDOWS 7.

9.2.2 Installation under WINDOWS

The CD-ROM includes an installation program for the setup software.

Installation

Autostart function activated:

Insert the CD-ROM into a free drive. A window with the start screen opens. There you find a link to the setup software DRIVE.EXE. Click it and follow the instructions.

Autostart function deactivated:

Insert the CD-ROM into a free drive. Click on **START** (task bar), then on **Run**. Enter the program call: **x:\index.htm** (x = correct CD drive letter).

Click OK and proceed as described above.

Connection to the serial interface of the PC

Connect the interface cable to a serial interface on your PC and the PC interface (X6) of the SERVOSTAR 600 (⇒ p. 69).

9.3 Quickstart Guide

9.3.1 Preparation

9.3.1.1 Unpacking, Mounting and Wiring the Servo Amplifier

1. Unpack servo amplifier and accessories
2. **Observe safety instructions in the manuals**
3. Mount the servo amplifier as described in chapter 7.3
4. Wire the servo amplifier as described in chapter 8.3 or apply the minimum wiring for drive testing as described in chapter 9.3.1.3
5. Install the software as described in chapter 9.2

9.3.1.2 Documents

You need access to these documents (located on the product CD-ROM, you can download the latest editions from our website):

- Instructions Manual (this manual)
- CANopen Communication Profile Manual
- Accessories Manual

Depending on the installed expansion card you need one of these documents:

- PROFIBUS DP Communication Profile Manual
- DeviceNet Communication Profile Manual
- SERCOS Communication Profile Manual
- EtherCAT Communication Profile Manual

You need Acrobat Reader to read the PDFs, an installation link is on every screen of the product CD-ROM.

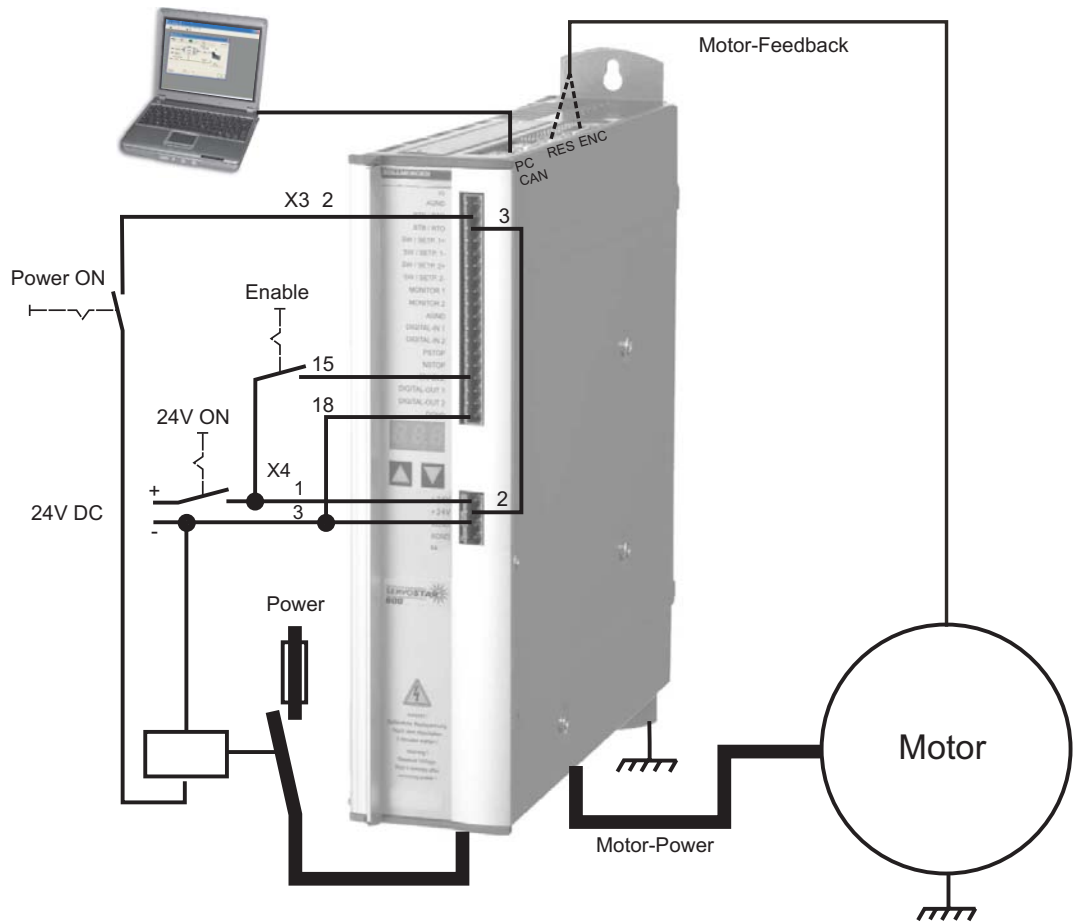

9.3.1.3 Minimum Wiring for Drive Test

CAUTION This wiring does not fulfill any requirements to safety or functionality of your application, it just shows the required wiring for drive testing without load.



9.3.2

Connect

- Connect the interface cable to a serial interface on your PC and to the serial interface X6 of the servo amplifier. USB to serial converter can be used optionally.
- Switch on the 24 V power supply for the servo amplifier.
- Wait about 30 seconds, until the front display of the servo amplifier displays the current classe (e.g.  for 3 amps). If the power supply voltage is switched on, too, a leading P is displayed (e.g.  for Power, 3 amps).

NOTE

If a fault code () or a warning () or a status message (./_ / E/S) appears in the display, you will find the description on page 88ff. If there is fault, fix the problem.



Double-Click the DRIVE.EXE icon on your Windows desktop to start the software.

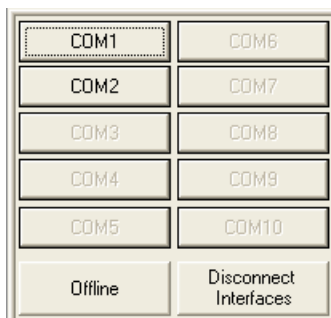

You can work offline or online with .
Work ONLINE now. Select the interface where the servo amplifier is connected to.

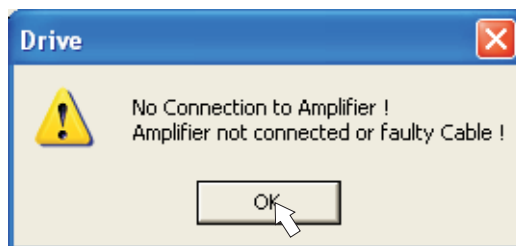

The software tries to communicate with the drive and to upload the parameters. If it's not successful, you receive this error message.

- Frequent causes:
- wrong interface chosen
 - wrong connector chosen at the servo amplifier
 - interface is used by another software
 - 24 V auxiliary voltage for the servo amplifier not working
 - interface cable broken or wrong wiring

Click OK to remove the error message. Detect and remove the error source. Restart the software.

If communication works, parameters are transmitted from the servoamplifier to the computer. Then you see the start screen.

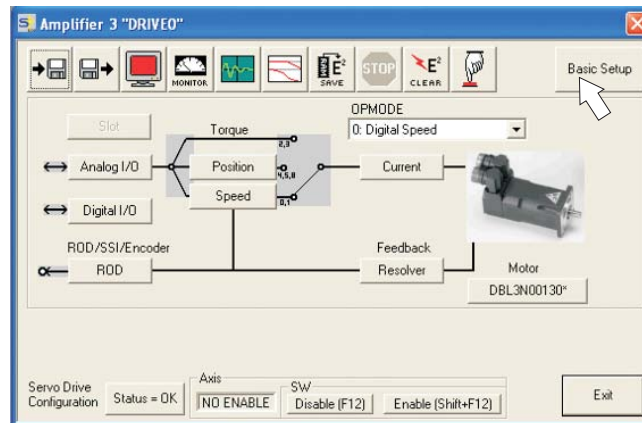

NOTICE

Make sure, that the amplifier is disabled (Input HW-Enable connector X3 pin 15 must be 0 V or open!)

9.3.3 Important Screen Elements

Help Function

The [online help](#) gives detailed information to all parameters the servo amplifier can work with.

Key F1	Starts online help for the actual screen page.
Menu Bar ? or Online HTML Help	Starts online help with table of contents.

Tool Bar



Save to EEPROM, required if you changed parameters.

Reset (coldstart), required if you changed important configuration parameters.

OPMODE
0: Digital Speed
Operation Mode, use Digital Velocity mode for drive testing.

SW
Disable (F12) Enable (Shift+F12)
Disable and Enable of the amplifier's output stage via software.

Status Bar

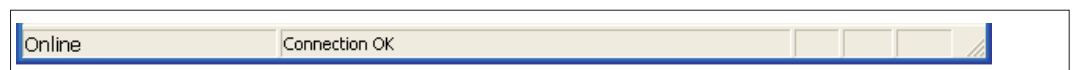

9.3.4 Basic Setup

On the start screen click "Basic Setup" button.

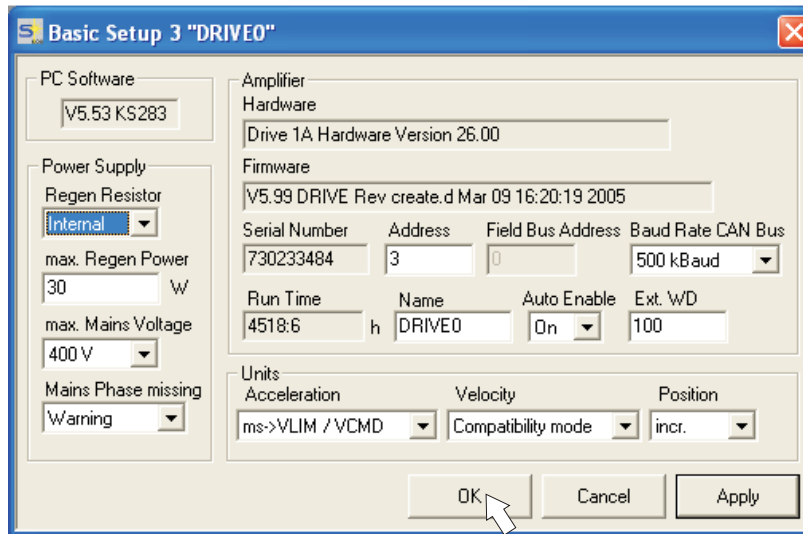

Regen Resistor: Change only if you use an external brake resistor. Most applications don't need an external brake resistor

max. Mains Voltage: Select the nominal mains AC voltage

Mains Phase Missing: You can select either warning "n05" or error "F19" in case of phase loss. The setting "F19" disables the output stage, "n05" is just a message.

Units: Acceleration, Velocity, Position

Select usable units for your application referring to the moved load.

Leave all other fields unchanged.

Click OK. On the start screen click "Motor" button.

9.3.5 Motor (synchronous)

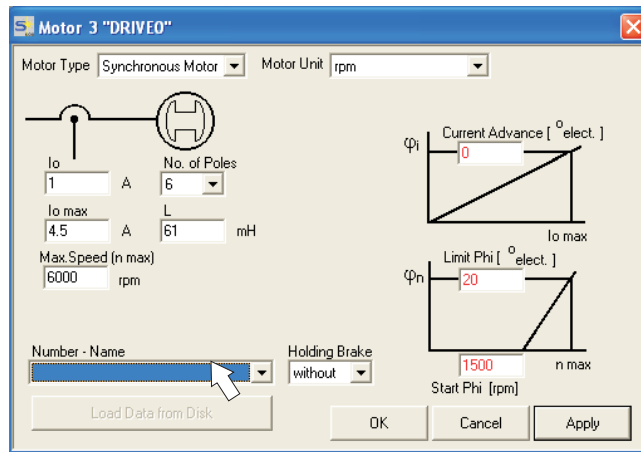

Press function key F12 (Software Disable) before changing motor parameters.

Motor Type: Select Synchronous Motor. If you use a linear motor or an induction motor, please contact our support department.

Number-Name: Click the list to start uploading the motor parameter table, which is stored in the servo amplifier. Search and select the connected motor. If your motor is not listed, please contact our support department.

Leave all other fields unchanged.

Click OK.

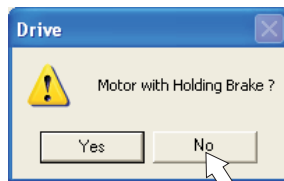

If your motor has a built-in brake, click Yes, otherwise "No".

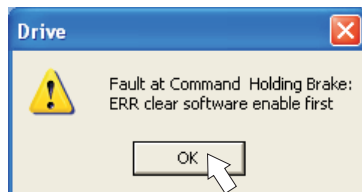

If Software Enable is active, a warning appears. You can proceed, but after the amplifier is restarted, you must check whether the holding brake configuration is correct. Click OK.

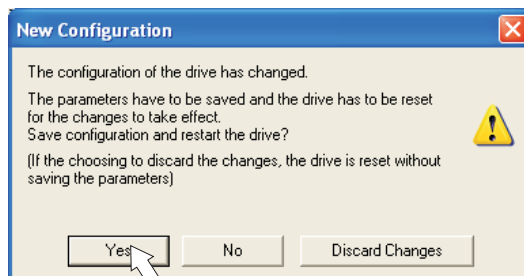

Parameters are uploaded to the amplifier's RAM now (takes some seconds). When this is done, you have to accept the changed configuration with "Yes" or to discard the changes in the appearing screen. If you click "Yes", the parameters are saved in the EEPROM and the amplifier makes a coldstart (reset). This takes some seconds.

On the start screen, click "Feedback" button.

9.3.6

Feedback

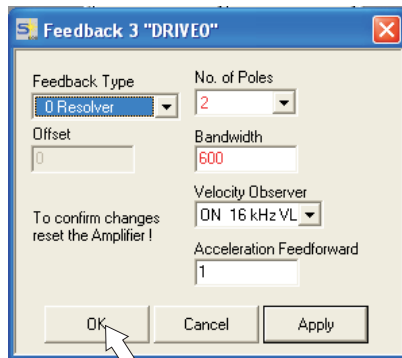

Press F12 (disable) before changing feedback parameters.

Feedback Type:

Select the feedback type used.

Leave all other fields unchanged.

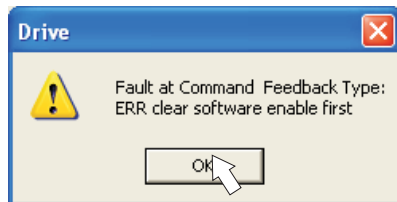

If Software Enable is active, a warning appears. The configuration change cannot be performed.

Click OK on the warnings, press F12 (SW disable) and start the Feedback procedure again.

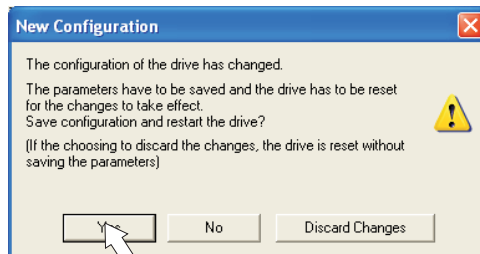

If everything was ok, the same procedure (parameter upload) that has been described for the motor selection starts.

If you click "Yes", the parameters are saved in the EEPROM and the amplifier makes a coldstart (reset). This takes some seconds.

9.3.7 Save Parameters and Restart

You are going to finish setup and you have changed several basic parameters. Depending on the parameters you changed, two possible reactions can occur:

Configuration parameters changed

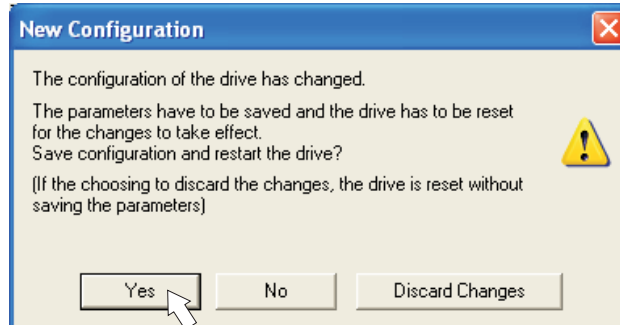

A warning appears, that you have to restart the amplifier. This is called "coldstart". Click "YES". The parameters are saved to the amplifier's EEPROM automatically and a reset command restarts the amplifier (takes a few seconds). For example, this happens after motor or feedback selection.

Other parameters changed

No warning appears. Parameters are saved in the volatile RAM only. Save the parameters to the EEPROM of the servo amplifier manually by clicking the symbol  in the tool bar. A coldstart of the amplifier is not necessary.

Reset the amplifier

You can reset the amplifier manually (e.g. in case of an error). Click the icon .

9.3.8 Jogging the Motor (Speed Control)

NOTICE

Be aware that the actual position of the load permits the subsequent moving operations. The axis could move to the hardware limit-switch or the mechanical stop. Make sure that a jerk or a fast acceleration of the load cannot cause any damage.

- Switch on the power supply for the drive.
- **Hardware-Enable:** +24 VDC to Enable [connector X3 pin 15].
- **Software-Enable:** Click the "Enable" button Enable (Shift+F12) on the start screen or use key combination Shift+F12. Now, the front display shows an E and the current rating (e.g. 0.00 for Enable, 3 amps).
- Click the icon "Oscilloscope" 
- Select Service-Mode "Speed F6", then click "Parameter" button Parameter

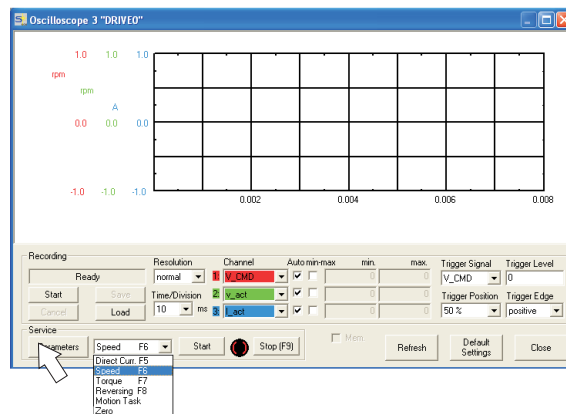

- Enter a safe speed. The sign defines the direction of movement.

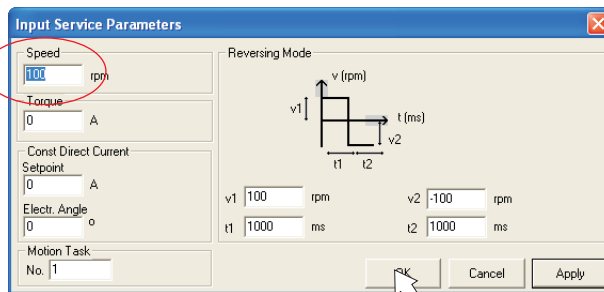

WARNING

Observe the "safe reduced speed" requirements for your application!

- Click OK.
- Start the service function ("Start" button or press F6). Click OK on the warning notice. Opmode is switched to "0" and the output stage is enabled automatically. The symbols color

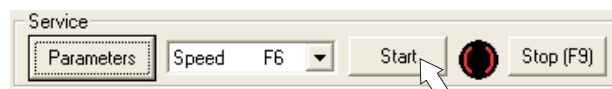

changes to green as long as the function is active.

- The function is active until you click the "Stop" button or press F9.
- The output stage can be disabled by pressing function key F12.

9.3.9 Status

Actual warnings and errors are listed on the **Status** screen, which can be accessed on the start screen by clicking the "Status" button. This button monitors the current status of the amplifier and can appear with different text.

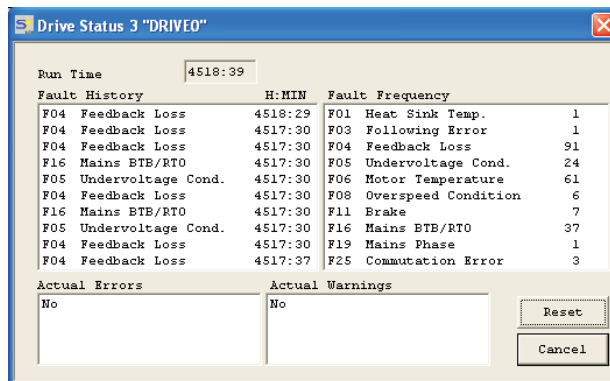
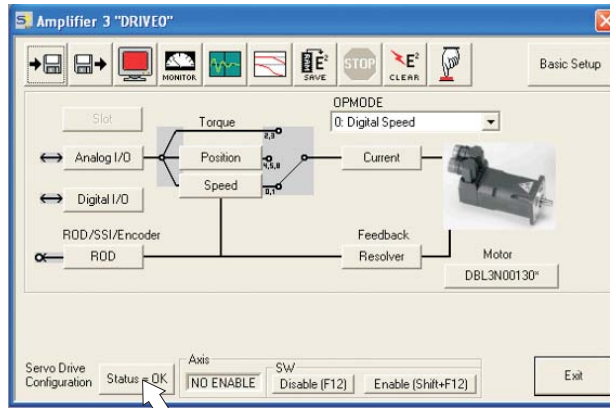

The Reset button can be used to clear some actual error messages. A description of errors/warnings can be found on page 88.

Now you have setup and tested the basic functions of the drive successfully.

9.3.10 Monitor

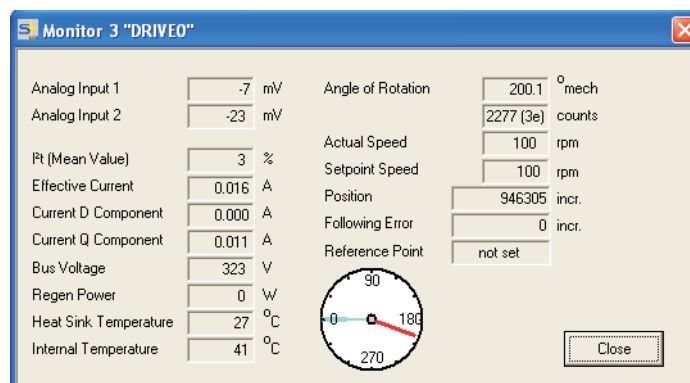

Click the icon "Monitor" 

The Monitor screen shows all important electrical and mechanical actual values

9.3.11 Additional Setup Parameters

Detailed information on all setup functions can be found in the [online help](#) system and the integrated command reference.

9.4 Multi-axis systems

Using a special multilink cable, you can connect up to six servo amplifiers together and to your PC :
Cable type -SR6Y- (for 4 amplifiers) or -SR6Y6- (for 6 amplifiers).

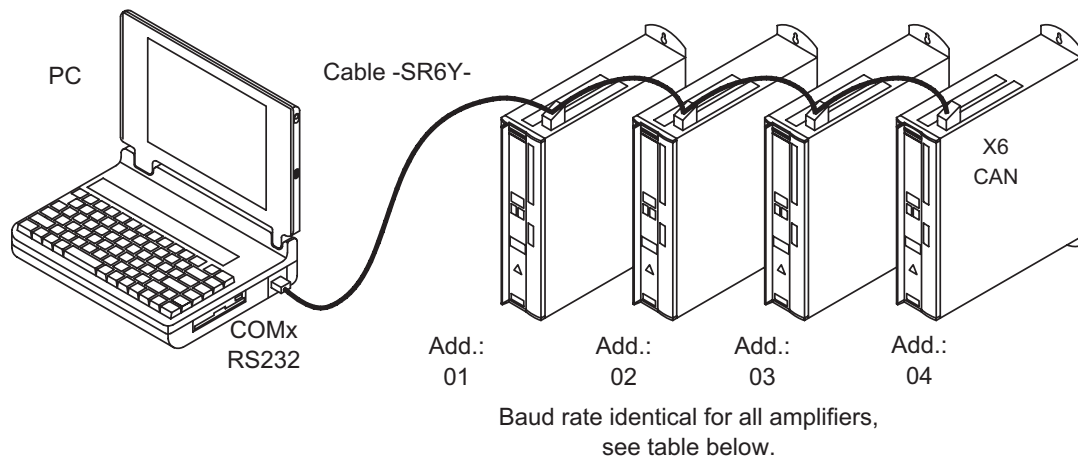

With the PC connected to just one servo amplifier you can now use the setup software to select all four / six amplifiers through the preset station addresses and set up the parameters.

9.4.1 Node address for CAN-bus

During setup it makes sense to preset the station addresses for the individual amplifiers and the baud rate for communication by means of the keypad on the front panel (⇒ p.87).

9.4.2 Baud rate for CAN-bus

NOTE

After changing the station address and baud rate you must turn the 24V auxiliary supply of the servo amplifier off and on again.

Coding of the baud rate in the LED display :

Coding	Baud rate in kbit/s	Coding	Baud rate in kbit/s
0	10	5	250
1	20	6	333
2	50	7	500
3	100	8	666
4	125	9	800
		10	1000

9.4.3 Example of connections for multi-axis system

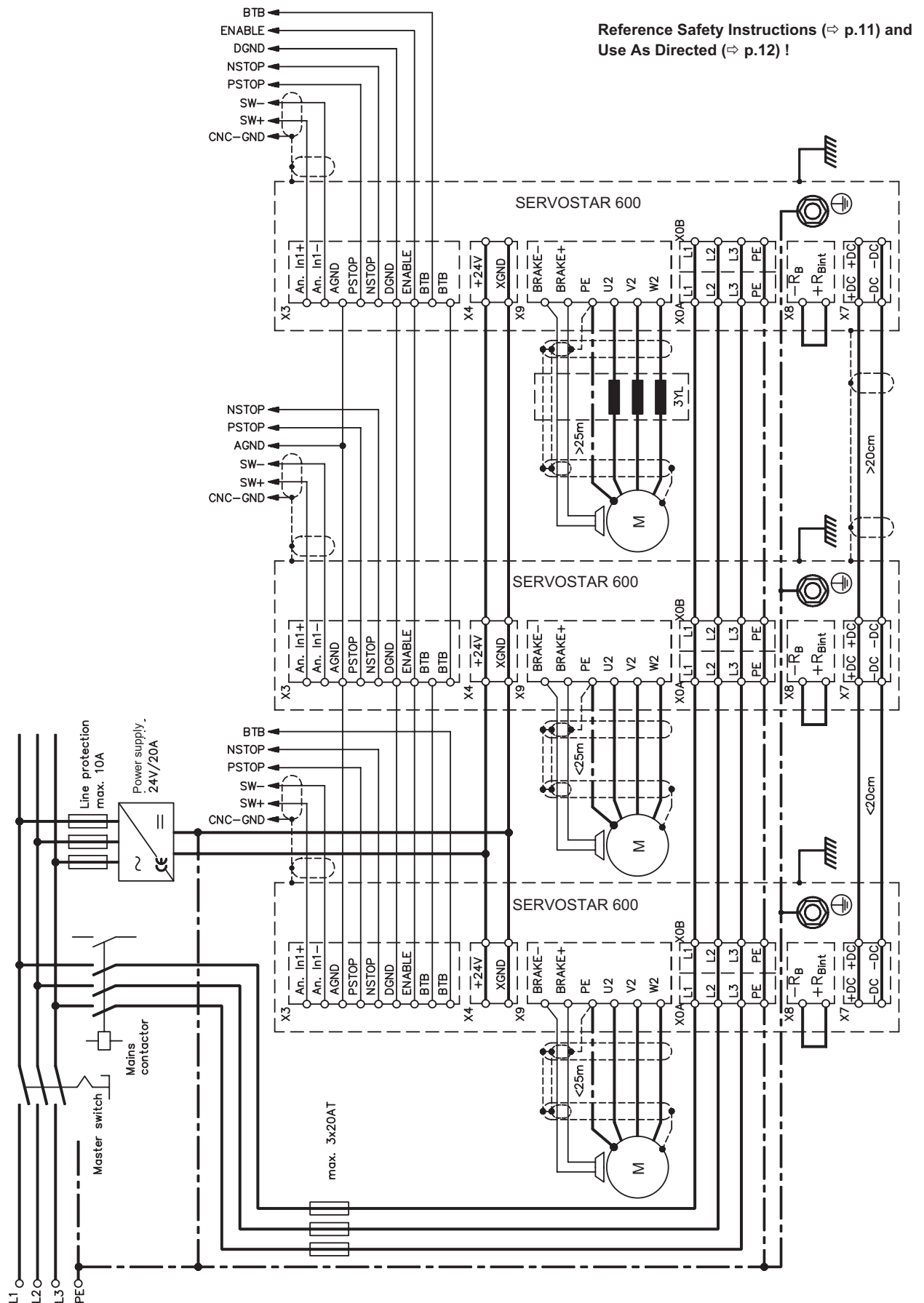

9.5 Key operation / LED display

In this chapter the two possible operation menus and the use of the keys in the front panel are shown. Normally, the SERVOSTAR 600 only places the standard menu at your disposal. If you want to attend the amplifier via the detailed menu, you must keep the right key pressed while switching on the 24V-supply.

9.5.1 Key operation

The two keys can be used to perform the following functions:

Key symbol	Functions
	press once : go up one menu item, increase number by one press twice in rapid succession : increase number by ten
	press once : go down one menu item, decrease number by one press twice in rapid succession : decrease number by ten
	press and hold right key, then press left key as well : enter a number, return function name

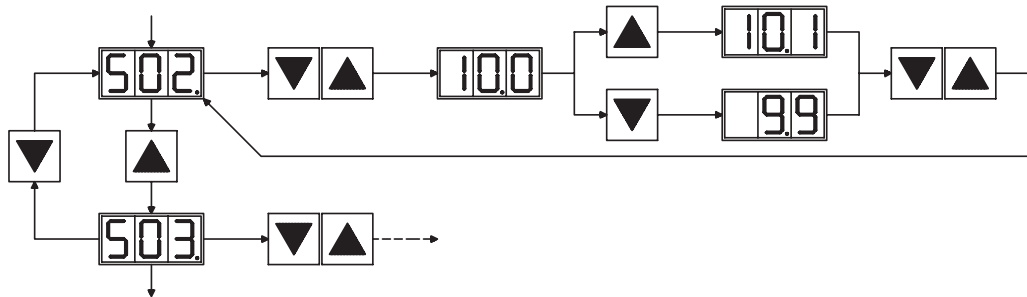

9.5.2 Status display

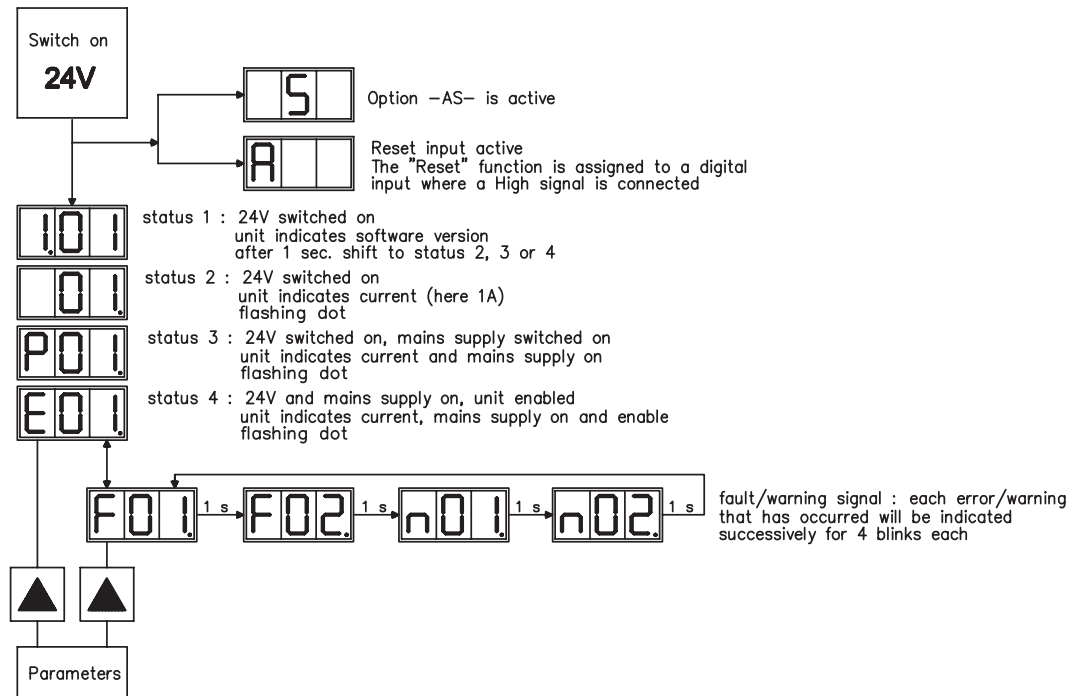

9.5.3 Standard menu structure

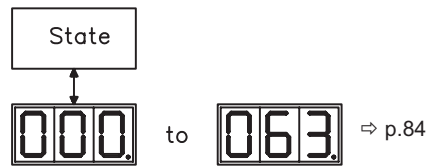

9.5.4 Extended menu structure

Keep the right key pressed while switching on the 24V-supply.

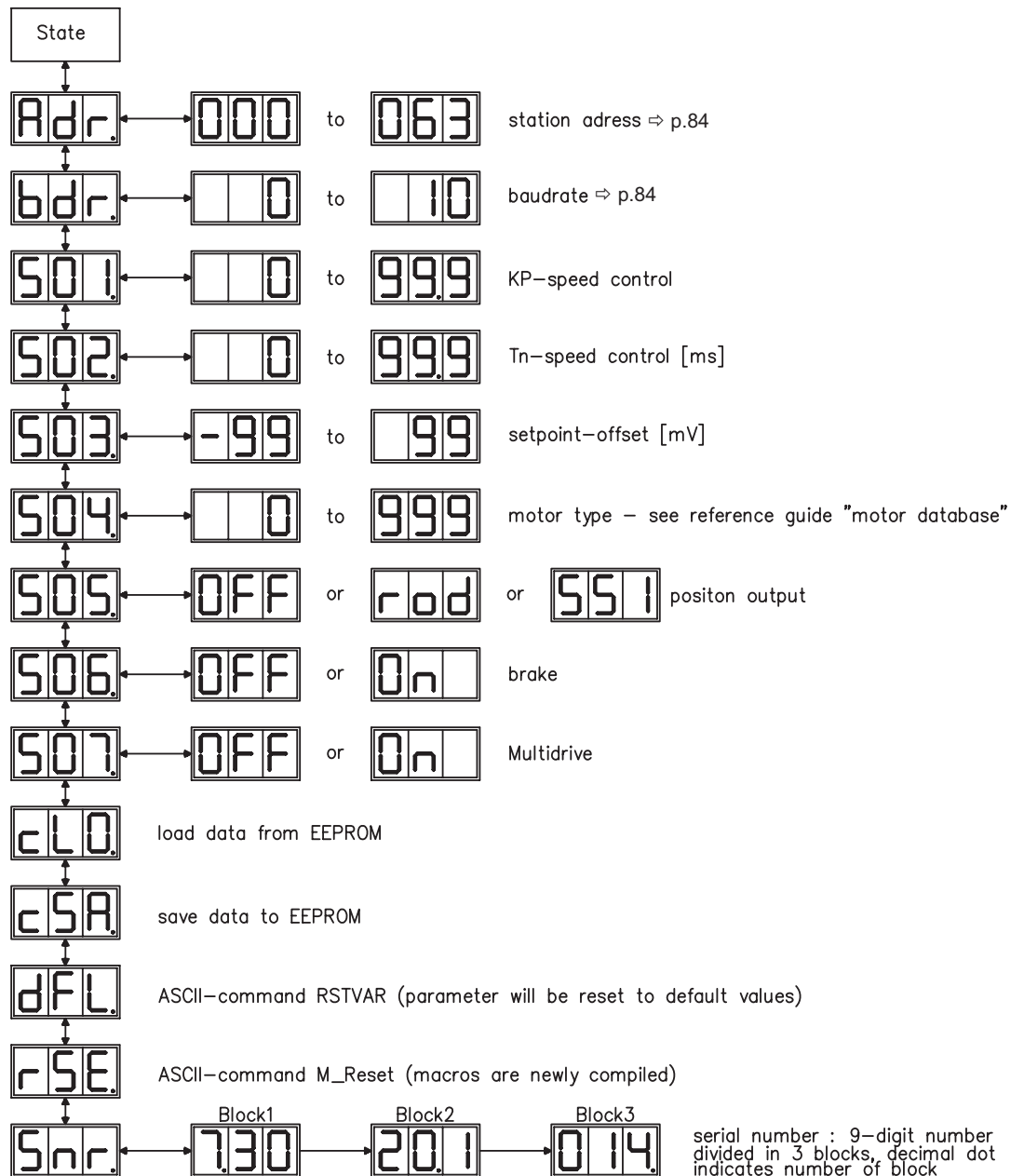

9.6 Error messages

Errors which occur are shown in coded form by an error number in the LED display on the front panel. All error messages result in the BTB/RTO contact being opened, and the output stage of the amplifier being switched off (motor loses all torque). If a motor-holding brake is installed, it will be activated.

Number	Designation	Explanation
E / S / A / P	Status Messages	Status messages, no error, see p. 86
. . .	Status Message	Updating the startup configuration
-	Status Message	Programming mode
F01*	Heat sink temperature	Heat sink temperature too high limit is set by manufacturer to 80°
F02*	Overvoltage	Overvoltage in DC bus link limit depends on the electrical supply voltage
F03*	Following error	Message from the position controller
F04	Feedback	Cable break, short-circuit, short to ground
F05*	Undervoltage	Undervoltage in DC bus link limit is set by manufacturer to 100V
F06	Motor temperature	Motor temperature too high or temp. sensor defect limit is set by manufacturer to 145°C
F07	Internal voltage supply	Internal amplifier supply voltages are out of tolerance
F08*	Overspeed	Motor runs away, speed is too high
F09	EEPROM	Checksum error
F10	Flash-EPROM	Checksum error
F11	Brake (motor)	Cable break, short-circuit, short to ground
F12	Motor phase	Motor phase missing (cable break or similar)
F13*	Internal temperature	Internal temperature too high
F14	Output stage	Fault in the power output stage
F15	I ² t max.	I ² t maximum value exceeded
F16*	Supply BTB/RTO	2 or 3 phases missing in the mains supply feed
F17	A/D converter	Error in the analog-digital conversion, normally caused by extreme electromagnetic interferences.
F18	Brake	Brake circuit faulty or incorrect setting
F19*	Supply phase	A phase is missing in the mains supply power feed (can be switched off for 2-phase operation)
F20	Slot fault	Slot error (hardware fault on expansion card)
F21	Handling error	Software error on the expansion card
F22	Earth short circuit	For 40/70 amps type only
F23	CAN-bus off	Severe CAN bus communication error
F24	Warning	Warning is displayed as fault
F25	Commutation error	Commutation error
F26	Limit switch	Homing error (machine has driven onto hardware limit switch)
F27	AS	Operational error with -AS- , input for AS-Enable and ENABLE have been set at the same time
F28	External Trajectory	External position profile generator created a step, that exceeded the maximum value
F29	Slot Fault	depends on expansion card, see online help
F30	Emergency timeout	Timeout emergency stop
F31	Macro	Macro program error
F32	System Error	system software not responding correctly

* = These error messages can be cancelled by the ASCII command CLRFAULT, without executing a reset. If only these errors are present, and the RESET button or the I/O-function RESET is used, the CLRFAULT command is also all that is carried out.

NOTE

More information to the messages can be found in the ASCII Object Reference ([online help](#)), see parameter ERRCODE. Hints for removal can be found in section "Trouble-Shooting" of the online help.

9.7 Warning messages

Faults which occur, but which do not cause a switch-off of the amplifier output stage (BTB/RTO contact remains closed), are indicated in the LED display on the front panel by a coded warning number.

Number	Designation	Explanation
E / S / A / P	Status Messages	Status messages, no error, see p. 86
. . .	Status Message	Updating the startup configuration
-	Status Message	Programming mode
n01	I ² t	I ² t threshold exceeded
n02	Brake power	Reached preset electrical brake power limit
n03*	S_fault	Exceeded preset following error limit
n04*	Response monitoring	Response monitoring (fieldbus) has been activated
n05	Supply phase	Mains supply phase missing
n06*	SW limit switch 1	Underrun software limit switch 1
n07*	SW limit switch 2	Overrun software limit switch 2
n08	Motion task error	A faulty motion task was started
n09	No reference point	No reference point (Home) set at start of motion task
n10*	PSTOP	PSTOP limit-switch activated
n11*	NSTOP	NSTOP limit-switch activated
n12	Motor default values loaded	Only for ENDAT or HIPERFACE® : discrepancy between motor number saved in the encoder and the amplifier, motor default values loaded
n13*	Slot warning	24V supply of the I/O expansion board is missing
n14	SinCos feedback	SinCos commutation (wake & shake) not completed, will be canceled when amplifier is enabled and wake & shake carried out
n15	Table error	Fault according to speed/current table INXMODE 35
n16	Summarized warning	Summarized warning for n17 to n31
n17	Fieldbus Synchronization	The mode synchronization SYNC SRC is selected but the drive isn't in synchronies cycle
n18	Multiturn overrun	Using Multiturn encoder feedback, an overrun over the maximum number of resolutions was detected
n19	Motion task ramps are limited	Range overflow on motion task data
n20	Wrong GMT data	Wrong "Graphical Motion Task" data
n21	PLC program error	For details see plc code
n22	max. motor temperatur reached	The user can shut down the process before the temperature error will interrupt the process immediately
n23...n31	reserved	reserved
n32	firmware beta version	Firmware is an unreleased beta version

* = These warning messages lead to a controlled shut-down of the drive (braking with the emergency ramp)

NOTE

More information to the messages can be found in the ASCII Object Reference ([online help](#)), see parameter STATCODE. Hints for removal can be found in section "Trouble-Shooting" of the online help.

9.8 Removing faults/warnings

Depending on the conditions in your installation, there may be a wide variety of reasons for the fault. In multi-axis systems there may be further hidden causes of a fault.

NOTE

Detailed hints for removal of faults can be found in the [online help](#) chapter "Trouble-Shooting".

Our customer service can give you further assistance with problems.

Fault	possible causes	Measures to remove the cause of the fault
HMI message: communication fault	<ul style="list-style-type: none"> — wrong cable used — cable plugged into wrong position in servo amplifier or PC — wrong PC interface selected 	<ul style="list-style-type: none"> — use null-modem cable — plug cable into the correct sockets on the servo amplifier and PC — select correct interface
motor does not rotate	<ul style="list-style-type: none"> — servo amplifier not enabled — break in setpoint cable — motor phases swapped — brake not released — drive is mechanically blocked — no. of motor poles set incorrectly — feedback set up incorrectly 	<ul style="list-style-type: none"> — apply enable signal — check setpoint cable — correct motor phase sequence — check brake control — check mechanism — set no. of motor poles — set up feedback correctly
motor oscillates	<ul style="list-style-type: none"> — gain too high (speed controller) — shielding in feedback cable is broken — AGND not wired up 	<ul style="list-style-type: none"> — reduce Kp (speed controller) — replace feedback cable — join AGND to CNC-GND
drive reports following error	<ul style="list-style-type: none"> — I_{rms} or I_{peak} is set to low — setpoint ramp is too long 	<ul style="list-style-type: none"> — increase I_{rms} or I_{peak} (keep within motor data !) — shorten setpoint ramp +/-
motor overheating	<ul style="list-style-type: none"> — I_{rms}/I_{peak} set too high 	<ul style="list-style-type: none"> — reduce I_{rms}/I_{peak}
drive too soft	<ul style="list-style-type: none"> — Kp (speed controller) too low — Tn (speed controller) too high — PID-T2 too high — T-Tacho too high 	<ul style="list-style-type: none"> — increase Kp (speed controller) — use motor default value for Tn (speed controller) — reduce PID-T2 — reduce T-Tacho
drive runs roughly	<ul style="list-style-type: none"> — Kp (speed controller) too high — Tn (speed controller) too low — PID-T2 too low — T-Tacho too low 	<ul style="list-style-type: none"> — reduce Kp (speed controller) — use motor default value for Tn (speed controller) — increase PID-T2 — increase T-Tacho
axis drifts at setpoint = 0V	<ul style="list-style-type: none"> — offset not correctly adjusted for analog setpoint provision — AGND not joined to the CNC-GND of the controls 	<ul style="list-style-type: none"> — adjust setpoint-offset (analogI/O) — join AGND and CNC-GND

10 Expansions / Accessories

10.1 Option -AS-, restart lock for personal safety

A frequently required application task is the protection of personnel against the restarting of drives. This can not be achieved by an electronic inhibit, but must be implemented with mechanical elements (positively driven relay contacts).

To get round this problem, up to now either the main contactor in the mains supply line was switched off, or another contactor was used to disconnect the motor from the servo amplifier.

The disadvantages of this method are :

- the DC bus link has to be charged up again at restart
- wear on the contacts of the contactors, caused by switching under load
- extensive wiring required, with additional switching components

The -AS- option avoids these disadvantages. A safety relay in the servo amplifier is activated either by the PLC or manually. Positively driven contacts provide a safe disconnection of the servo amplifier, the setpoint input of the servo amplifier is inhibited, and a signal is sent to the safety circuit.

The suggested circuits (⇒ p. 95) fulfills safety category 1 (EN 954-1) or category 3 with additional safety relay (e.g. PNOZ of PILZ company).

Advantages of the -AS- option

- the DC bus link remains charged up, since the mains supply line remains active
- only low voltages are switched, so there is no contact wear
- very little wiring is required
- the functionality and the personnel safety when using the circuit recommendations in this documentation have been approved by the Trade Liability Association.

Moving single axes or axis-groups in setting-up operation

In setting-up operation, people will frequently be within the danger zone of the machinery. Axes will normally be moved under the control of permission switches. An additional switch-off of the unused axes, by means of the restart lock, increases the safety margin and avoids the repeated switching of main contactors or motor contactors.

Switching off grouped axes with separate working areas

Even when several SERVOSTAR 600 are operating off a common mains supply and DC bus link, it is possible to set up groups for separate working areas. These groups can then be switched off separately for personnel safety.

10.1.1 Safety instructions

▲ WARNING

- Observe "Use as directed" on page 92.
- The monitoring contacts (KSO1/2) for each amplifier with an -AS- option must be looped into the control circuit. This is vital, so that a malfunction of the internal safety relay or a cable break can be recognized.
- If the -AS- option is automatically activated by a control system (KSI1/2), then make sure that the output of the control is monitored for possible malfunction. Can be used to prevent a faulty output from activating the -AS- option while the motor is running.
- It is vital to keep to the following functional sequence when the -AS- option is used:
 1. Brake the drive in a controlled manner (speed setpoint = 0V)
 2. When speed = 0 rpm, disable the servo amplifier (enable = 0V)
 3. If there is a suspended load, apply an additional mechanical block to the drive
 4. Activate the -AS- option

10.1.2 Use as directed

The -AS- restart lock is **exclusively** intended to provide safety for personnel, by preventing the restart of a system. To achieve this personnel safety, the wiring of the safety circuits must meet the safety requirements of EN60204, EN12100 and EN 954-1.

The -AS- restart lock must **only** be activated,

- when the motor is no longer rotating (setpoint = 0V, speed = 0rpm, enable = 0V).
Drives with a suspended load must have an additional safe mechanical blocking (e.g. by a motor-holding brake).

- when the monitoring contacts (KSO1/2) for all servo amplifiers are wired into the control signal loop.

The -AS- restart lock may **only** be controlled by a CNC if the control of the internal safety relay is arranged for redundant monitoring.

The -AS- restart lock must **not** be used if the drive is to be made inactive for the following reasons :

- 1.- cleaning, maintenance and repair operations or long inoperative periods
In such cases, the entire system should be disconnected from the supply by the personnel, and secured (main switch).
- 2.- emergency-stop situations
In an emergency-stop situation, the main contactor is switched off (by the emergency-stop button).

10.1.3 Block diagram

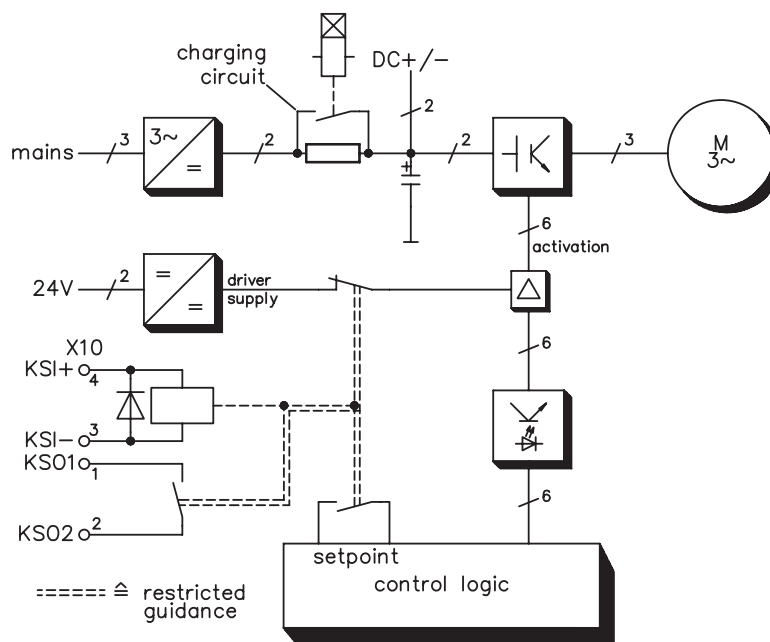

10.1.4 Functional description

An additional connector (X10) is mounted on the front panel of the SERVOSTAR 600. The coil connections and a make (n.o.) contact of a safety relay are made available through 4 terminals on this connector.

The 24VDC safety relay in the servo amplifier (approved) is controlled externally. All the relay contacts have positive action.

Two contacts switch off the driver supply of the output stage in the servo amplifier, and short the internal setpoint signal to AGND (0 V).

The make (n.o.) contact used for monitoring is looped into the control circuit.

If the safety relay is not energized, then the monitoring contact is open and the servo amplifier is ready for operation.

If the drive is electronically braked, the servo amplifier is disabled and the motor-holding brake is on, then the safety relay is energized (manually or by the controls).

The supply voltage for the driver circuit of the output stage is switched off in a safe manner, the internal setpoint is shorted to 0V, and the monitoring contact bridges the safety logic in the control circuit of the system (monitoring of protective doors etc.)

Even if the output stage or driver is destroyed, it is impossible to start the motor.

If the safety relay itself is faulty, then the monitoring contact cannot bridge the safety logic of the system. Opening the protective devices will then switch off the system.

10.1.5 Signal diagram (sequence)

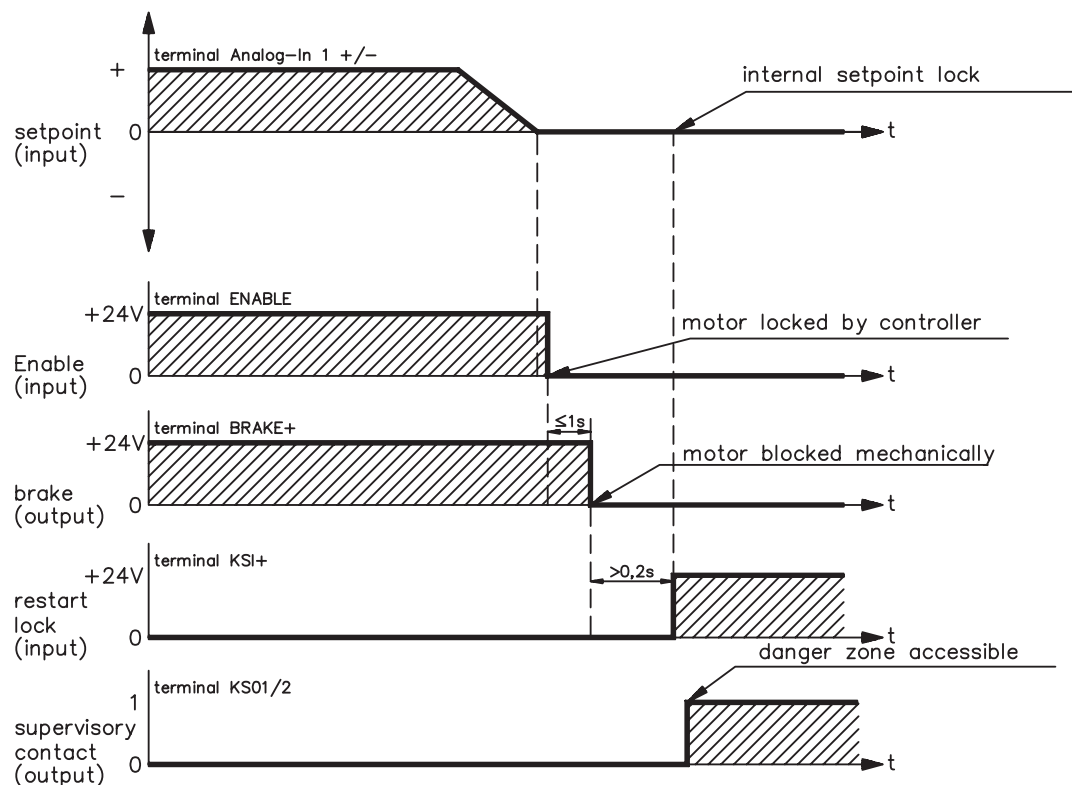

10.1.6 Functional test

⚠ WARNING The functioning of the restart lock must be tested during setup, after every alteration in the wiring of the system, or after exchanging one or more components of the system.

1. Stop all drives, with setpoint 0V, disable drives, mechanically block any suspended loads
2. Activate the -AS- option.
3. Open protective screens (but do not enter hazardous area)
4. Pull off the X10 connector from an amplifier: **the mains contactor must drop out**
5. Reconnect X10. Switch on mains contactor again.
6. Repeat steps 4 and 5 for each individual servo amplifier.

10.1.7 Connection diagram (principle)

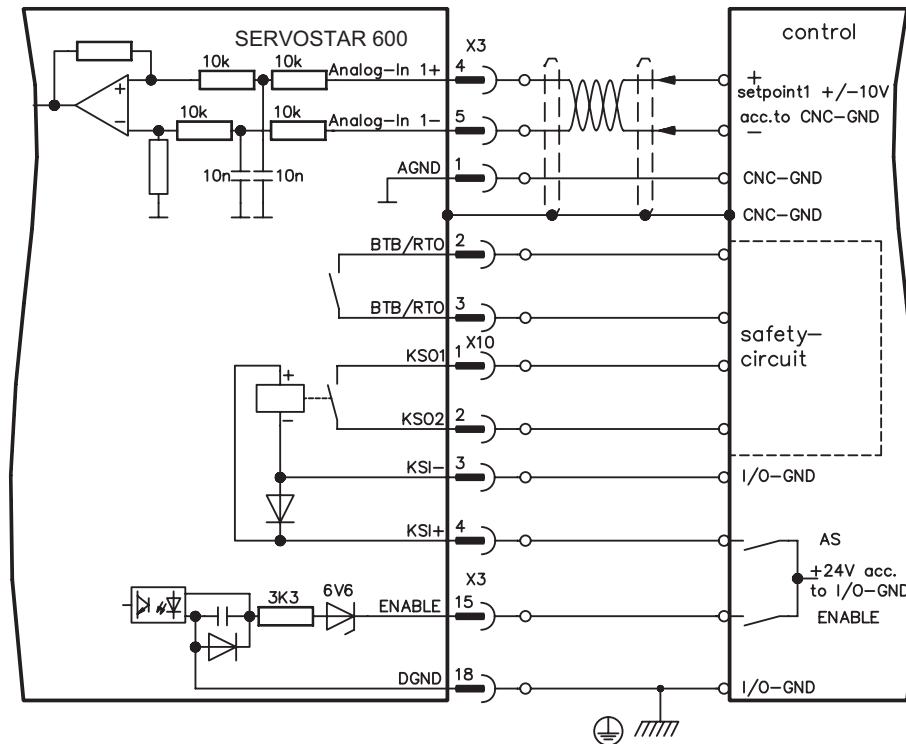

NOTE

Application examples for category 1 see chapter 10.1.8.

10.1.8 Application example category 1 according to EN954-1

Flowchart for stop and emergency stop category 0.

10.1.8.1 Control circuit

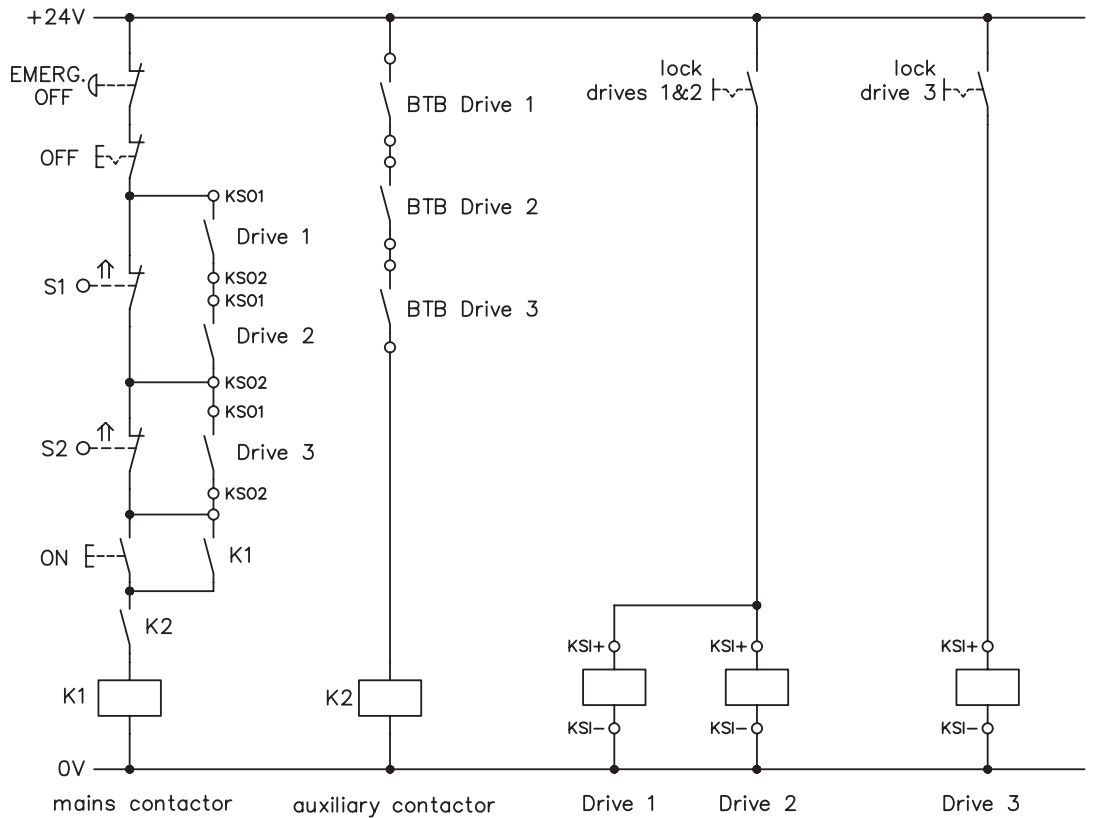

10.1.8.2 Mains supply circuit

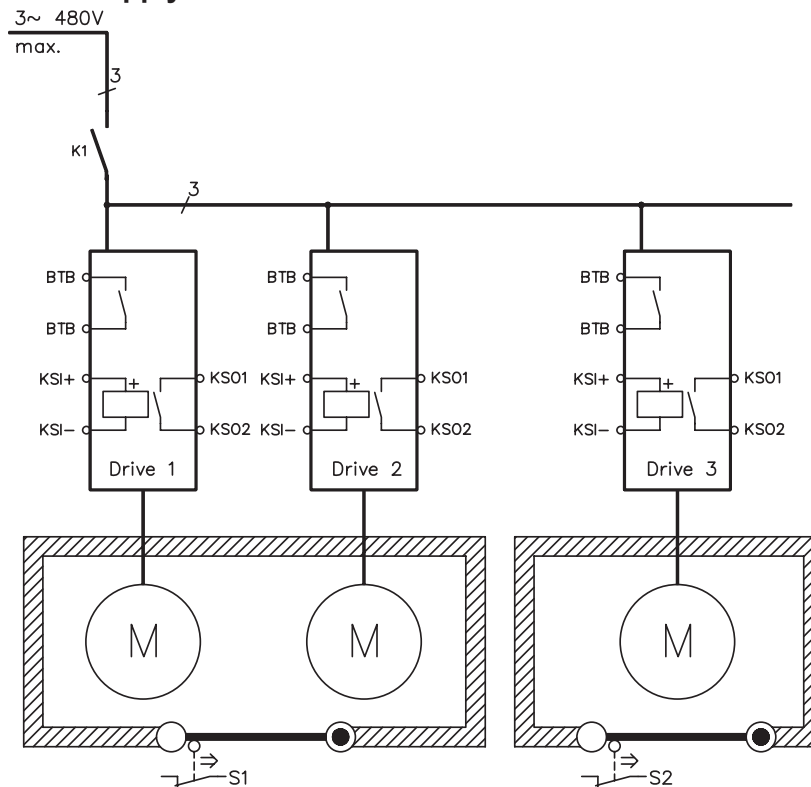

10.1.9 Application example category 3 according to EN954-1

Flowchart for stop and emergency stop category 1.

10.1.9.1 Control circuit

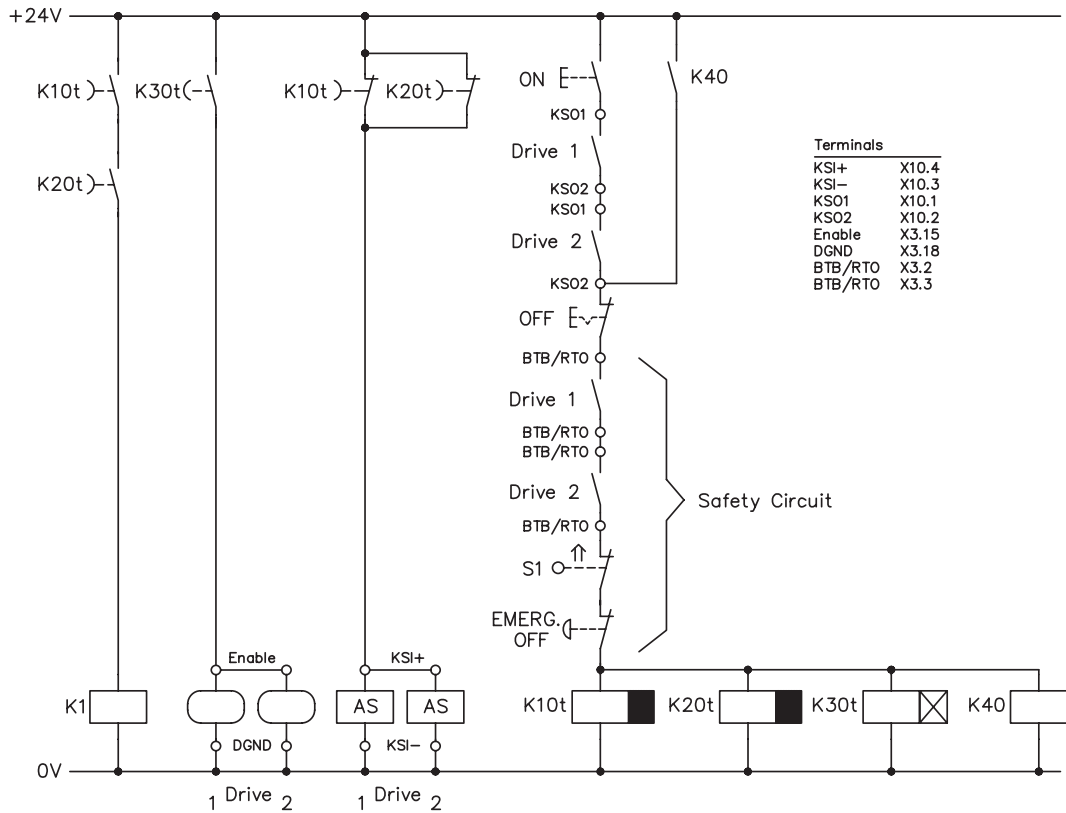

10.1.9.2 Mains supply circuit

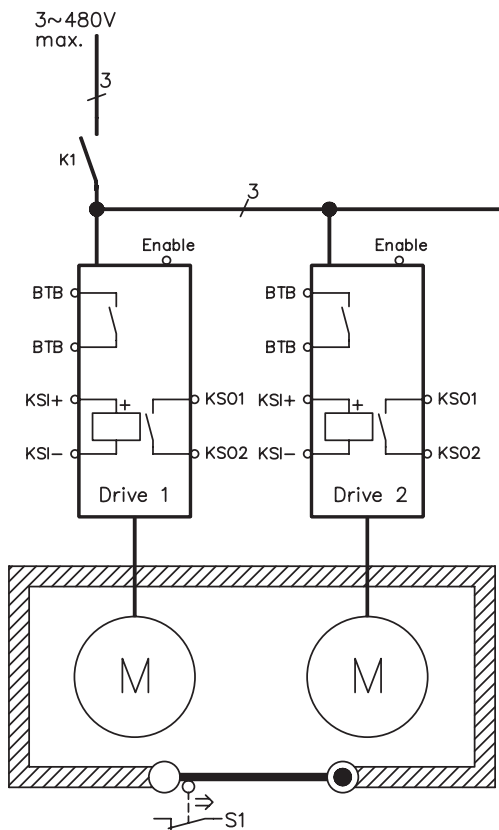

10.1.9.3

Flow chart

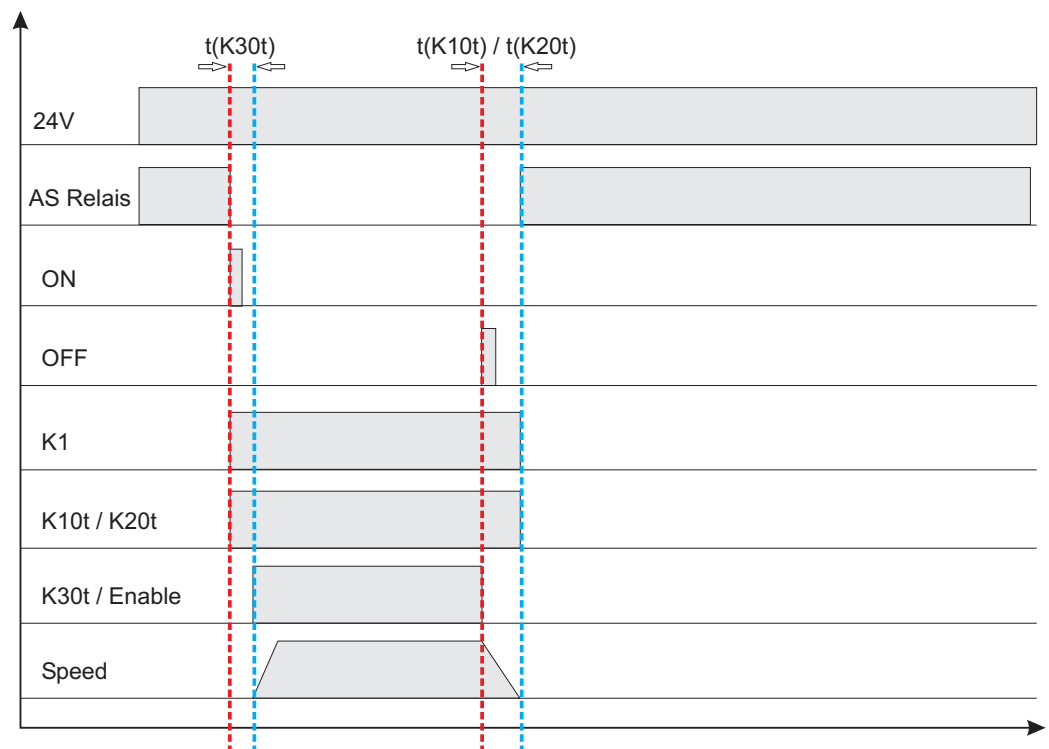

$t(K30t) \geq 500ms$

$t(K10t)$ and $t(K20t)$ ensure that the drive remains active until the axis has come to a standstill. This time depends on the application and must exceed the deceleration ramp.

NOTE

The drive must have been brought to a safe standstill by the time $t(K10t)$ and $t(K20t)$ have elapsed. After this point, active braking with the servo amplifier is no longer possible.

10.2 Expansion Cards

Information about availability and order numbers can be found on p. 117

10.2.1 Guide to installation of expansion cards

- Use a suitable screwdriver to lever off the cover of the option slot.
- Take care that no small items (such as screws) fall into the open option slot.

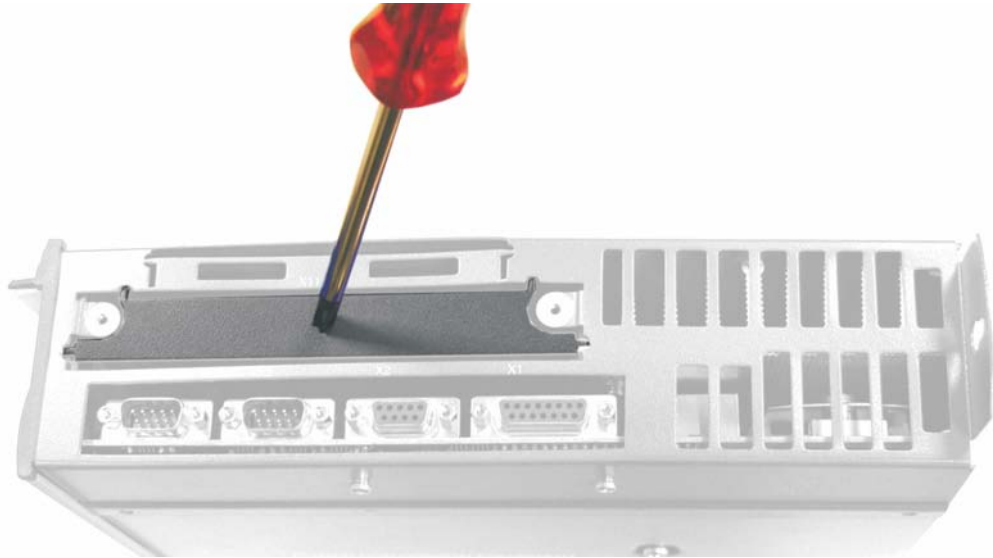

- Push the expansion card carefully into the provided guide rails of the slot, without twisting it.

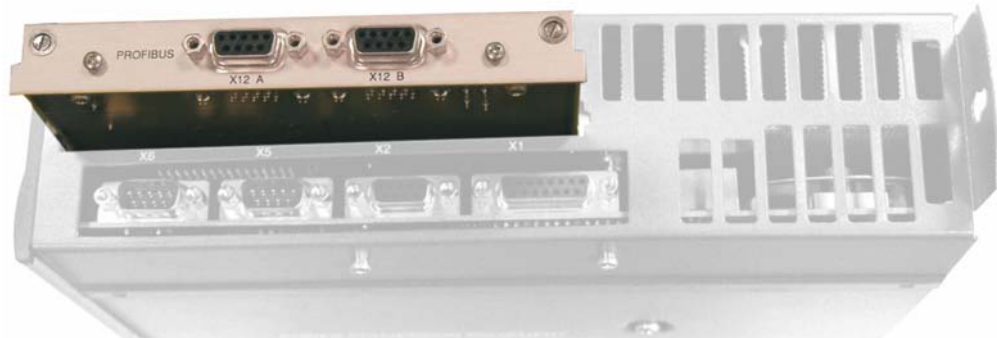

- Press the expansion card firmly into the slot, until the front cover touches the fixing lugs. This ensures that the connectors make good contact.
- Screw the screws on the front cover into the threads in the fixing lugs.

10.2.2 Expansion card -I/O-14/08-

This chapter describes the I/O-expansion card -I/O-14/08-. It only describes the additional features that the expansion card makes available for the SERVOSTAR 600.

The -I/O-14/08- provides you with 14 additional digital inputs and 8 digital outputs. The functions of the inputs and outputs are fixed. They are used to initiate the motion tasks that are stored in the servo amplifier and to evaluate signals from the integrated position control in the higher-level control.

The functions of the inputs and signal outputs correspond exactly to the functions that can be assigned to the digital-I/O on connector X3 of the SERVOSTAR 600.

The 24VDC supply for the expansion card is taken from the controller. All inputs and outputs are electrically isolated from the servo amplifier by optocoupler.

10.2.2.1 Front view



10.2.2.2 Technical data

Control inputs	24 V / 7 mA, PLC-compatible
Signal outputs	24 V / max. 500 mA, PLC-compatible
Supply inputs, to IEC 61131	24 V (18 ... 36 V) / 100 mA plus total current of the outputs (depends on the input wiring of the controls) The 24 VDC voltage has to be supplied by an electrically isolated power supply, e.g. with insulating transformer.
Fusing (external)	4 AT
Connectors	MiniCombicon, 12-pole, coded on PIN1 and 12 respectively
Cables	Data – up to 50m long : 22 x 0.5mm ² , unshielded, Supply – 2 x 1mm ² , check voltage drop
Waiting time between 2 motion tasks	depends on the response time of the control system
Addressing time (min.)	4 ms
Starting delay (max.)	2 ms
Response time of digital outputs	max. 10 ms

10.2.2.3 Light emitting diodes (LEDs)

Two LEDs are mounted next to the terminals on the expansion card. The green LED signals that the 24 V auxiliary supply is available for the expansion card. The red LED signals faults in the outputs from the expansion card (overload, short-circuit).

10.2.2.4 Select motion task number (Sample)

Motion task no.	A7	A6	A5	A4	A3	A2	A1	A0
binary 1010 1110	1	0	1	0	1	1	1	0
decimal 174	128	-	32	-	8	4	2	-

10.2.2.5 Connector assignments

Connector X11A			
Pin	Dir	Function	Description
1	In	A0	Motion task no., LSB
2	In	A1	Motion task no., 2 ¹
3	In	A2	Motion task no., 2 ²
4	In	A3	Motion task no., 2 ³
5	In	A4	Motion task no., 2 ⁴
6	In	A5	Motion task no., 2 ⁵
7	In	A6	Motion task no., 2 ⁶
8	In	A7	Motion task no., MSB
9	In	Reference	Polls the reference switch. If a digital input on the basic unit is used as a reference input, then the input on the I/O expansion card will not be evaluated.
10	In	FError_clear	Clear the warning of a following error (no3) or the response monitoring (n04).
11	In	Start_MT Next	The following task, that is defined in the motion task by "Start with I/O" is started. The target position of the present motion task must be reached before the following task can be started. The next motion block can also be started by an appropriately configured digital input on the basic unit.
12	In	Start_Jog v=x	Start of the setup mode "Jog Mode" with a defined speed. After selecting the function, you can enter the speed in the auxiliary variable "x". The sign of the auxiliary variable defines the direction. A rising edge starts the motion, a falling edge cancels the motion.

Connector X11B			
1	In	MT_Restart	Continues the motion task that was previously interrupted. The motion task can also be continued by an appropriately configured digital input on the basic unit.
2	In	Start_MT I/O	Start of the motion task that has the number that is presented, bit-coded, at the digital inputs (A0 to A7). The digital function with the same name, in the basic unit, starts the motion task with the address from the digital inputs on the basic unit.
3	Out	InPos	When the target position for a motion task has been reached (the InPosition window), this is signaled by the output of a HIGH-signal. A cable break will not be detected
4	Out	Next-InPos	The start of each motion task in an automatically executed sequence of motion tasks is signaled by an inversion of the output signal. The output produces a Low signal at the start of the first motion task of the motion task sequence. The form of the message can be varied by using ASCII commands.
		PosReg0	Can only be adjusted by ASCII commands.
5	Out	$\overline{\text{FError}}$	A LOW signal indicates that the position has gone outside the acceptable following error window.
6	Out	PosReg1	The preset function of the corresponding position register is indicated by a HIGH-signal.
7	Out	PosReg2	
8	Out	PosReg3	
9	Out	PosReg4	
10	Out	PosReg5	Can only be adjusted by ASCII commands.
11	Supply	24VDC	auxiliary supply voltage
12	Supply	I/O-GND	Digital-GND for the controls

10.2.2.6 Connection diagram

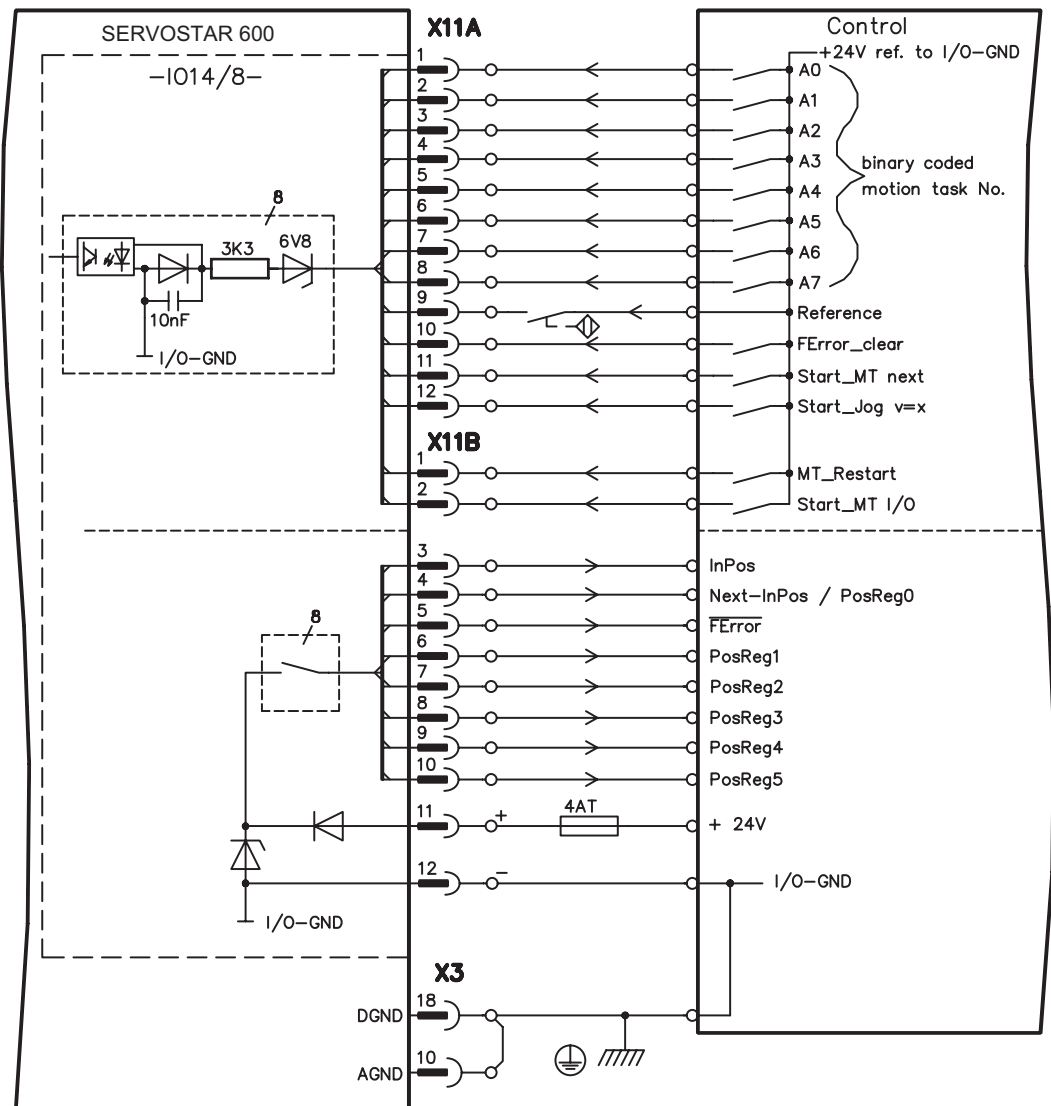

NOTE AGND and DGND (connector X3) must be joined together !

10.2.3 Expansion cards -PROFIBUS-

This chapter describes the PROFIBUS expansion card for the SERVOSTAR 600. Information on the range of functions and the software protocol can be found in the manual "Communication profile PROFIBUS DP". The PROFIBUS expansion card has two 9-pin Sub-D sockets wired in parallel. The supply voltage for the expansion card is provided by the servo amplifier.

10.2.3.1 Front view



10.2.3.2 Connection technology

Cable selection, cable routing, shielding, bus connector, bus termination and transmission times are described in the "Installation guidelines for PROFIBUS-DP/FMS" from PNO, the PROFIBUS User Organization.

10.2.3.3 Connection diagram

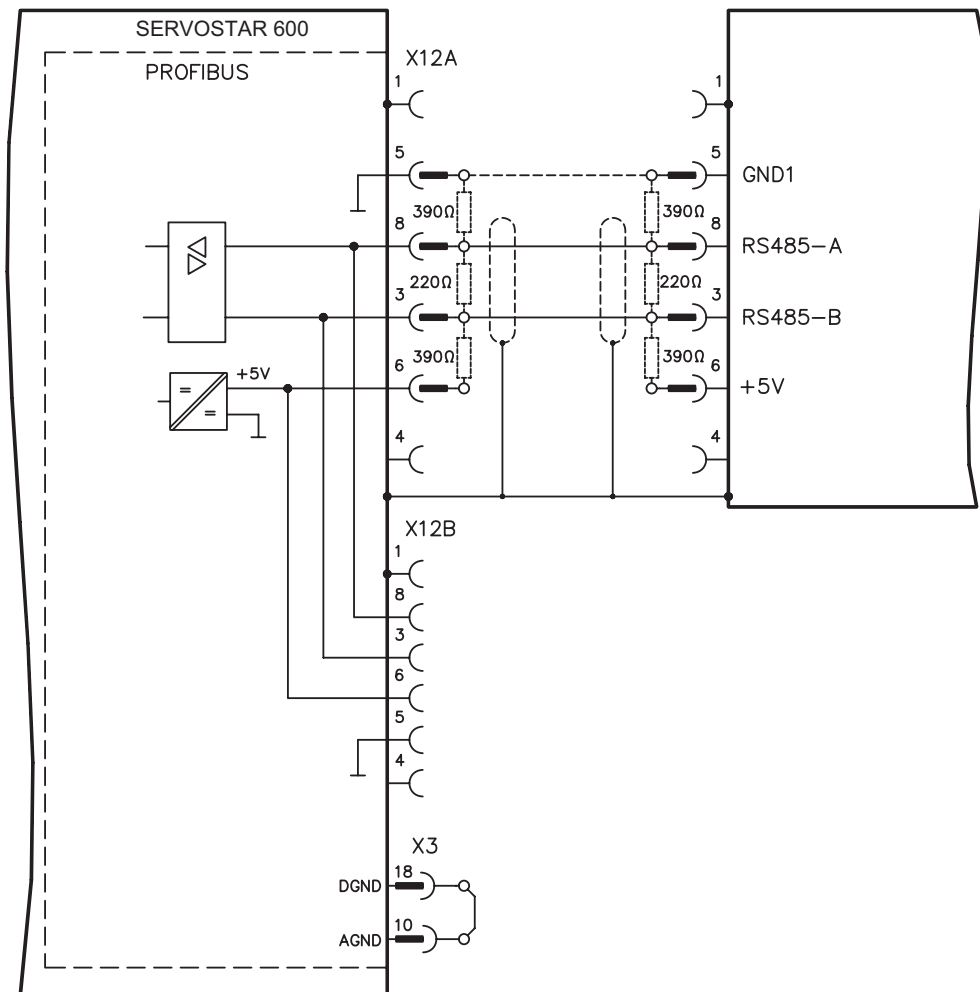

NOTE AGND and DGND (connector X3) must be joined together !

10.2.4 Expansion card -SERCOS-

This chapter describes the SERCOS expansion card for SERVOSTAR 600. Information on the range of functions and the software protocol can be found in the manual "IDN Reference Guide SERCOS".

10.2.4.1 Front view



10.2.4.2 Light emitting diodes (LEDs)

RT	indicates whether SERCOS telegrams are being correctly received. In the final Communication Phase 4 this LED should flicker, since cyclical telegrams are being received.
TT	indicates that SERCOS telegrams are being transmitted. In the final Communication Phase 4 this LED should flicker, since cyclical telegrams are being transmitted. Check the stations addresses for the controls and the servo amplifier if: - the LED never lights up in SERCOS Phase 1 or - the axis cannot be operated, although the RT LED is lighting up cyclically.
ERR	indicates that SERCOS communication is faulty or suffering from interference. If this LED is very bright, then communication is suffering strong interference, or is non-existent. Check the SERCOS transmission speed for the controls and the servo amplifier (BAUDRATE) and the fibre-optic connection. If this LED flickers, this indicates a low level of interference for SERCOS communication, or the optical transmitting power is not correctly adjusted to suit the length of cable. Check the transmitting power of the (physically) previous SERCOS station. The transmitting power of the servo amplifier can be adjusted in the setup software DRIVE.EXE on the SERCOS screen page, by altering the parameter for the cable length.

10.2.4.3 Connection technology

For the fiber optic cable connection, only use SERCOS components to the SERCOS Standard IEC 61491.

Receive data

The fiber optic cable carrying receive data for the drive in the ring structure is connected to X13 with an F-SMA connector.

Transmit data

Connect the fiber optic cable for the data output to X14 with an F-SMA connector.

10.2.4.4 Connection diagram

Layout of the SERCOS bus system in ring topology, with optical fibre cables (schematic).

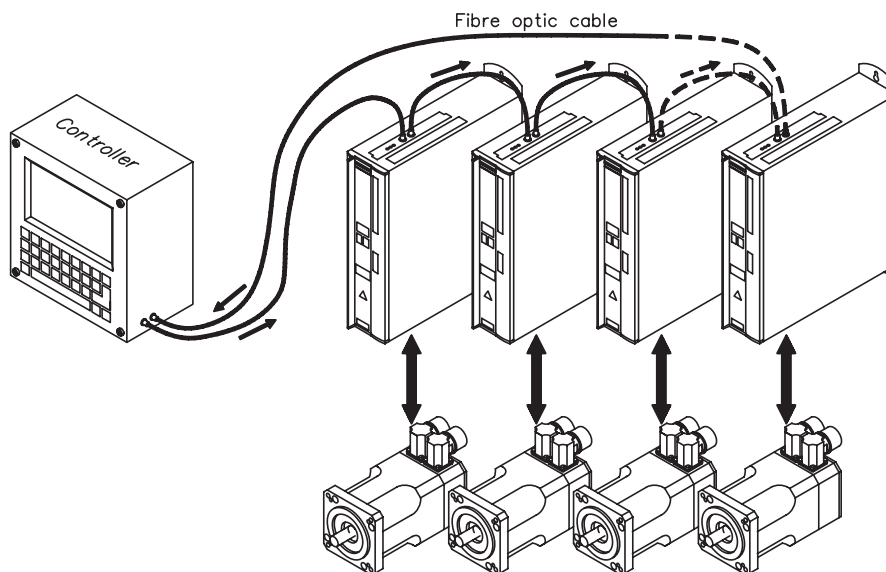

NOTE

AGND and DGND (connector X3) must be joined together !

10.2.4.5 Modifying the station address

The drive address can be set to a value between 0 and 63. With address 0, the drive is assigned as an amplifier in the SERCOS ring. There are various ways to set the station address:

Keys on the front of the servo amplifier

The SERCOS address can also be modified using the keys on the front (p. 87).

Setup software

The address can also be modified in the setup software. For additional information, please refer to the "Setup software" [online help](#). Alternatively, enter the command **ADDR #** in the "Terminal" screen, where # is the new address of the drive.

10.2.4.6 Modifying the baud rate and optical power

If the baud rate is not set correctly, communication is not possible. The **SBAUD #** parameter can be used to set the baud rate, where # is the baud rate.

If the optical power is not set correctly, errors occur in telegram transmission and the red LED on the drive lights up. During normal communication, the green send and receive LEDs flash, giving the impression that the relevant LED is on. The **SLEN #** parameter can be used to specify the optical range for a standard 1 mm² glass fibre cable, where # is the length of the cable in metres.

SBAUD		SLEN	
2	2 Mbaud	0	Very short connection
4	4 Mbaud	1... < 15	Length of the connection with a 1 mm ² plastic cable
8	8 Mbaud	15... < 30	Length of the connection with a 1 mm ² plastic cable
16	16 Mbaud	³ 30	Length of the connection with a 1 mm ² plastic cable

Setup software

The parameters can be modified in the setup software, "SERCOS" screen. For additional information, please refer to the "Setup software" [online help](#). Alternatively, the commands **SBAUD #** and **SLEN #** can be entered in the "Terminal" screen.

10.2.5 Expansion card -DEVICENET-

This section describes the DeviceNet expansion card for SERVOSTAR 600. Information on the range of functions and the software protocol can be found in our manual "DeviceNet Communication Profile".

10.2.5.1 Front view

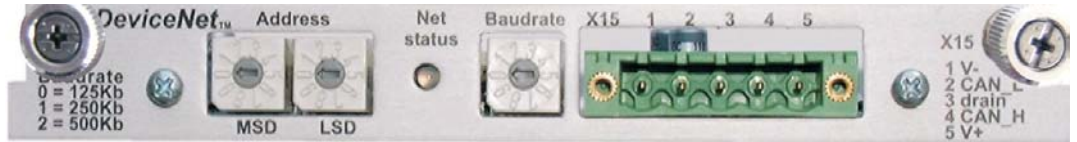

10.2.5.2 Connection technology

Cable selection, cable routing, shielding, bus connector, bus termination and transmission times are all described in the "DeviceNet Specification, Volume I, II", published by ODVA.

10.2.5.3 Connection diagram

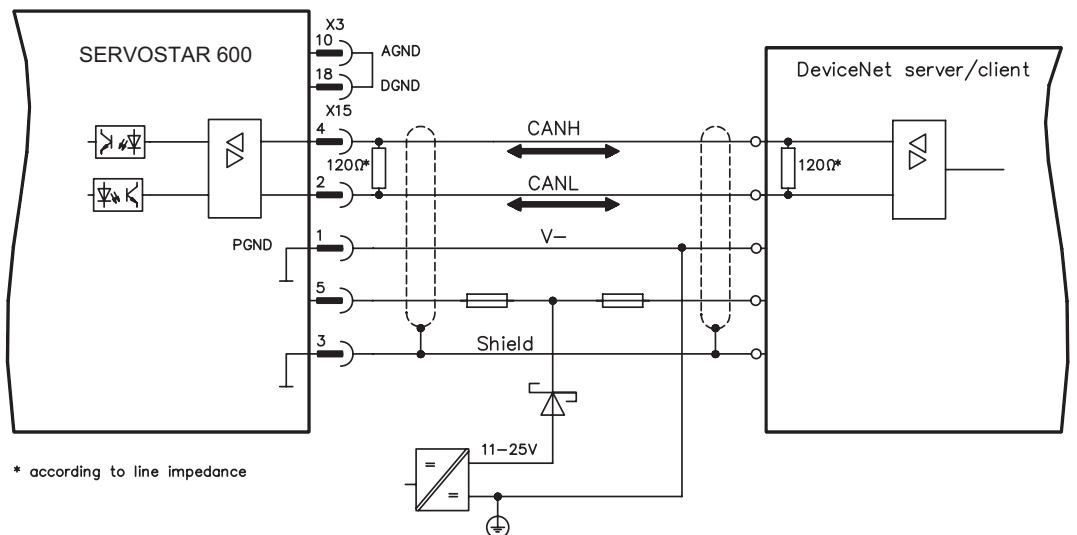

NOTE AGND and DGND (connector X3) must be joined together !

10.2.5.4 Combined module/network status-LED

LED	Meaning
off	The device is not online. - The device has not yet finished the Dup_MAC_ID test. - The device is possibly not yet switched on.
green	The device is operating as normal, is online, and the connections have been established. The device has been assigned to a master.
blinking green	The device is operating as normal, is online, but the connections have not been established. - The device has passed the Dup_MAC_ID test and is online, but the connection to other nodes have not been established. - This device has not been assigned to a master. - Missing, incomplete or wrong configuration.
blinking red	An error that can be cleared and/or at least one I/O connection are in a waiting state.
red	- An error has occurred that cannot be cleared; it may be necessary to replace the device. - Communication device failure. The device has detected a fault that prevents communication with the network (for instance, a MAC ID appears twice or BUSOFF).

10.2.5.5 Setting the station address (device address)

The station address for the servo amplifier can be set in three different ways:

- Set the rotary switches at the front of the expansion card to a value between 0 and 63. Each switch represents a decimal figure. For example, to set the address for the drive to 10, set MSD to 1 and LSD to 0.
- Set the rotary switches at the front of the expansion card to a value higher than 63. Now you can set up the station address by using the ASCII commands DNMACID x, SAVE, COLD-START, whereby "x" stands for the station address.
- Set the rotary switches at the front of the expansion card to a value higher than 63. Now you can set up the station address by using the DeviceNet Object (Class 0x03, Attribute 1). This is normally carried out with the help of a DeviceNet software setup tool. You must save the parameters in non-volatile memory (Class 0x25, Attribute 0x65) and then restart the drive after setting/altering the address.

10.2.5.6 Setting the transmission speed

The DeviceNet transmission speed can be set in three different ways:

- Set the rotary switch for Baud rate (at the front of the option card) to a value between 0 and 2. 0 = 125 kbit/s, 1 = 250 kbit/s, 2 = 500 kbit/s.
- Set the rotary switch for Baud rate (at the front of the option card) to a value higher than 2. Now you can set the Baud rate by using the terminal commands DNBAUD x, SAVE, COLD-START, whereby "x" stands for 125, 250 or 500 .
- Set the rotary switch for Baud rate (at the front of the option card) to a value higher than 2. Now you can set the Baud rate by using the DeviceNet Object (Class 0x03, Attribute 2) to a value between 0 and 2. This is normally carried out with the help of a DeviceNet software setup tool. You must save the parameters in non-volatile memory (Class 0x25, Attribute 0x65) and then restart the drive after altering the baud rate.

10.2.5.7 Bus cable

To meet ISO 898, a bus cable with a characteristic impedance of 120 Ω should be used. The maximum usable cable length for reliable communication decreases with increasing transmission speed. As a guide, you can use the following values which we have measured, but they are not to be taken as assured limits.

General characteristic	Specification
Bit rates	125 kbit, 250 kbit, 500 kbit
Distance with larger bus connections	500 meters at 125 kBaud 250 meters at 250 kBaud 100 meters at 500 kBaud
Number of nodes	64
Signal environment	CAN
Modulation	Basic bandwidth
Coupling medium	DC-coupled differential transmit/receive operation
Isolation	500 V (option: optocoupler on the transceiver's node side)
Typical differential input impedance (recessive state)	Shunt C = 5pF Shunt R = 25KΩ (power on)
Min. differential input impedance (recessive state)	Shunt C = 24pF + 36 pF/m of the permanently attached stub cable Shunt R = 20KΩ
Absolute max. voltage range	-25 V to +18 V (CAN_H, CAN_L) The voltages for CAN_H and CAN_L refer to the ground pin of the transceiver. The voltage is higher than that on the V-terminal by the amount of the forward voltage drop of the Schottky diode. This voltage drop must be < 0.6 V.

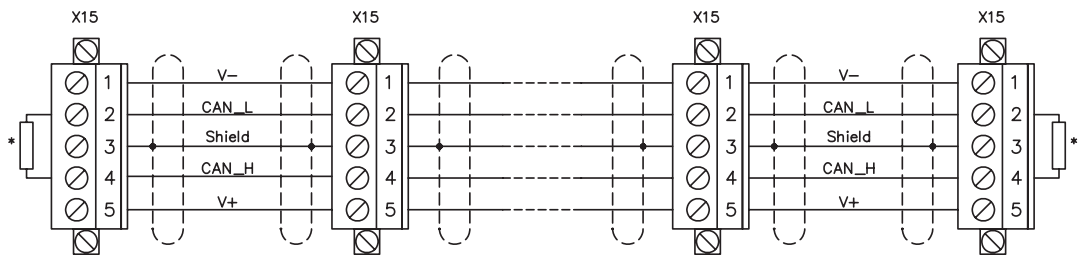

* according to line impedance about 120Ω

Grounding:

The DeviceNet network must only be grounded at one point, to avoid ground loops. The circuitry for the physical layer in all devices are referenced to the V-bus signal. The ground connection is made via the power supply for the bus system. The current flowing between V- and ground must not flow through any device other than the power supply.

Bus topology:

The DeviceNet medium utilizes a linear bus topology. Termination resistors are required at each end of the connecting cable. Stub cables are permitted up to a length of 6 meters, so that at least one node can be connected.

Termination resistors:

DeviceNet requires a termination **at each end** of the connecting cable. These resistors must meet the following requirements: 120 Ω, 1% metal-film, 1/4 W

10.2.6 Expansion card -EtherCAT-

This section describes the EtherCAT expansion card for SERVOSTAR 600. Information on the range of functions and the software protocol can be found in the EtherCAT documentation. This expansion card enables the servo amplifier to be connected to the EtherCAT network via RJ-45 connectors (IN and OUT ports).

10.2.6.1 Front view



10.2.6.2 LEDs

LED	Function
ERROR	flickering = Booting Error blinking = Invalid Configuration single flash = Unsolicited State Change double flash = Watchdog Timeout off = No Error
RUN	on = Device is in state OPERATIONAL blinking = Device is in state PRE-OPERATIONAL single flash = Device is in state SAFE-OPERATIONAL off = Device is in state INIT
ACT IN	on = linked, but not active at X20A (in) flickering = linked and active at X20A (in) off = not linked at X20A (in)
ACT OUT	on = linked, but not active at X20B (out) flickering = linked and active at X20B (out) off = not linked at X20B (out)

10.2.6.3 Connection diagram

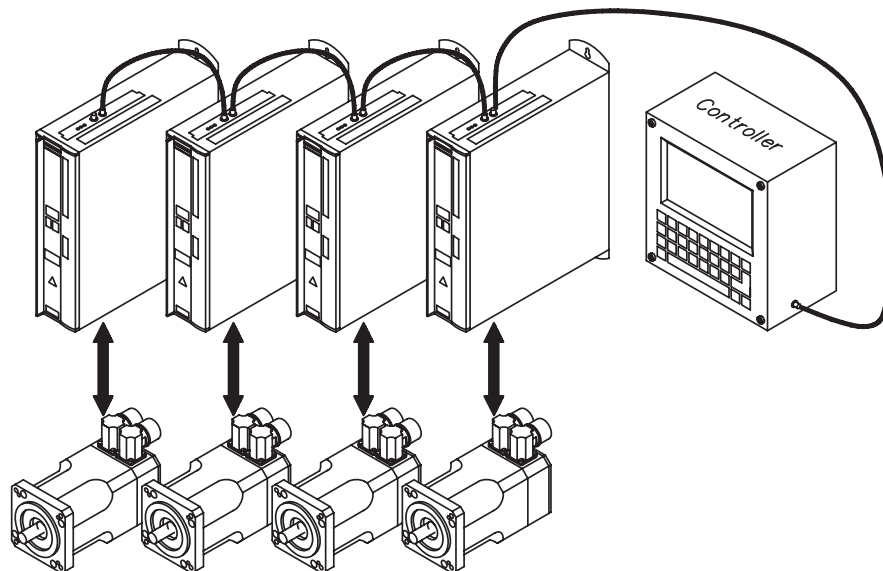

NOTE AGND and DGND (connector X3) must be joined together !

10.2.7 Expansion card -SYNQNET-

This section describes the SynqNet expansion card for SERVOSTAR 600. Information on the range of functions and the software protocol can be found in the SynqNet documentation.

10.2.7.1 Front view

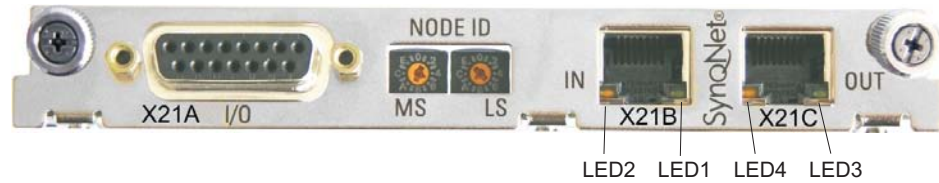

10.2.7.2 NODE ID Switch

With these hexadecimal switches you can set the main and low significant bytes of the Node ID separately. SynqNet does not require an address for correct operation in the network, however in some machines this can be a convenient way of identifying build options to the application program.

10.2.7.3 Node LED table

LED#	Name	Function
LED1, green	LINK_IN	ON = receive valid (IN port) OFF = not valid, power off, or reset.
LED2, yellow	CYCLIC	ON = network cyclic BLINK = network not cyclic OFF = power off, or reset
LED3, green	LINK_OUT	ON = receive valid (OUT port) OFF = not valid, power off, or reset
LED4, yellow	REPEATER	ON = repeater on, network cyclic BLINK = repeater on, network not cyclic OFF = repeater off, power off, or reset

10.2.7.4 SynqNet Connection, Connector X21B/C (RJ-45)

Connection to the SynqNet network via RJ-45 connectors (IN and OUT ports) with integrated LEDs.

10.2.7.5 Digital inputs/outputs, connector X21A (SubD 15-pin, socket)

Inputs (In): 24V (20...28V), opto-isolated, one high-speed input (Pin 4)
 Outputs (Out): 24V, opto-isolated, Darlington driver

Pinout connector X21A (SubD 15 pin)			
Pin	Type	Description	
1	In	+24V	power supply
2	Out	NODEALARM	indicates a problem with the node
3	Out	OUT_01	digital output
4	In	IN_00 (fast)	capture input (fast)
5	In	IN_04	digital input
6	In	IN_01	digital input
7	In	HOME	reference switch
8	In	POSLIM	limit switch, positive direction
9	In	GND	power supply
10	Out	OUT_00	digital output
11	Out	OUT_02	digital output
12	In	IN_02	digital input
13	In	IN_03	digital input
14	In	NEGLIM	limit switch, negative direction
15	In	NODEDISABLE	disables Node

10.2.7.6 Connection diagram digital inputs/outputs, connector X21A

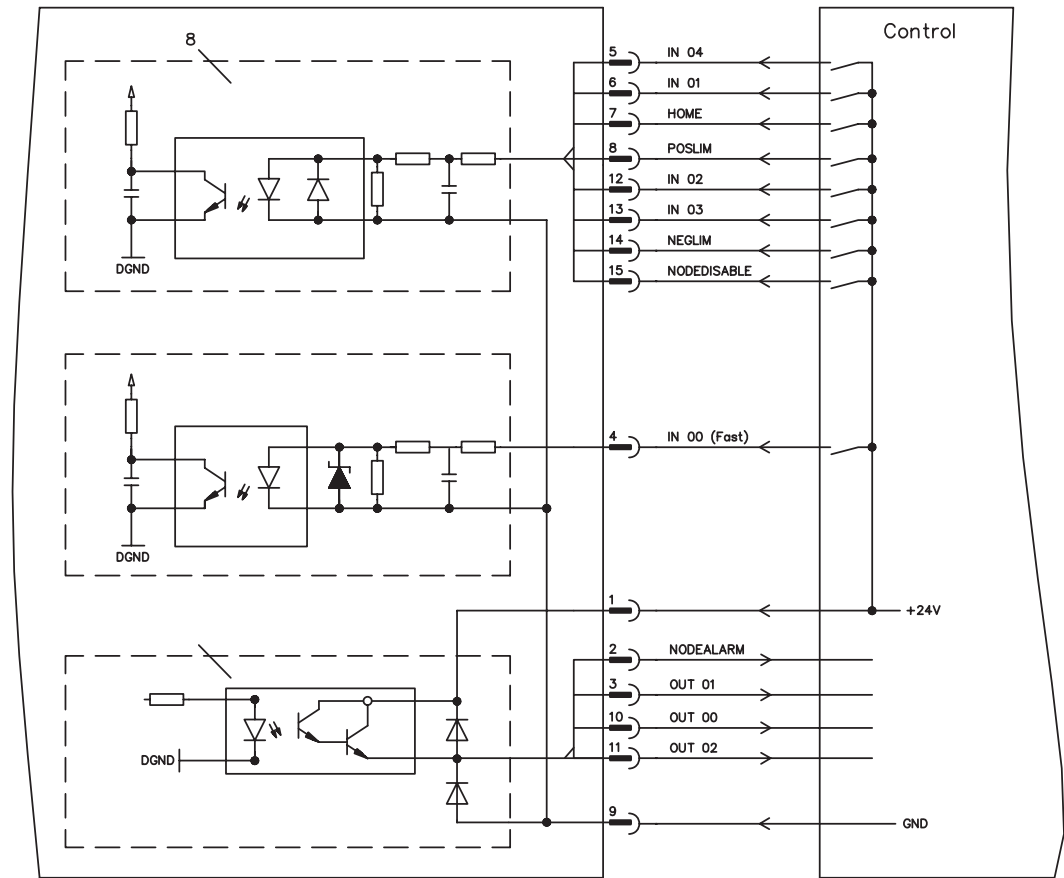

NOTE AGND and DGND (connector X3) must be joined together !

10.2.8 Expansion module -2CAN-

Connector X6 of the SERVOSTAR 6xx is assigned to the signals for the RS232 interface and the CAN interface. It is therefore not the standard pin assignment for these interfaces, and a special cable is required to be able to use both interfaces simultaneously.

The -2CAN- expansion module provides the interfaces on separate Sub-D connectors. The two CAN connectors are wired in parallel. A termination resistor (120 Ω) for the CAN bus can be switched into circuit if the SERVOSTAR 6xx is at the end of the bus.

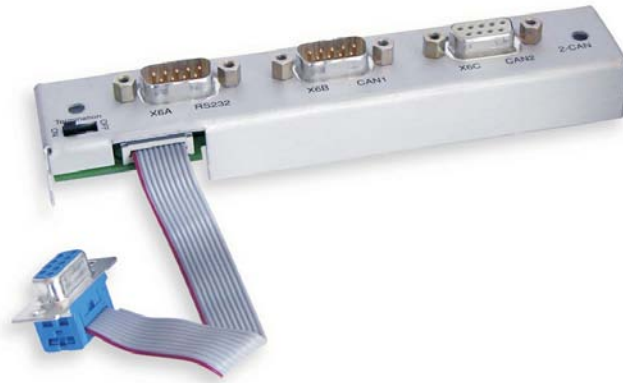

10.2.8.1 Installation

NOTE

The modul must be placed onto the option slot after levering off the cover of the option slot:

- Screw the distance pieces into the fixing lugs of the option slot.
- Place the expansion module onto the option slot.
- Screw the screws into the threads of the distance pieces.
- Plug the Sub-D9 socket into connector X6 on the SERVOSTAR 600

10.2.8.2 Front View



10.2.8.3 Connection technology

Standard shielded cables can be used for the RS232 and CAN interfaces.

NOTE

If the servo amplifier is the last device on the CAN bus, then the switch for the bus termination must be set to ON.

Otherwise, the switch must be set to OFF (condition as delivered).

10.2.8.4 Connector assignments

RS232		CAN1=CAN2	
X6A Pin	Signal	X6B=X6C Pin	Signal
1	Vcc	1	
2	RxD	2	CAN-Low
3	TxD	3	CAN-GND
4		4	
5	GND	5	
6		6	
7		7	CAN-High
8		8	
9		9	

10.2.8.5 Connection diagram

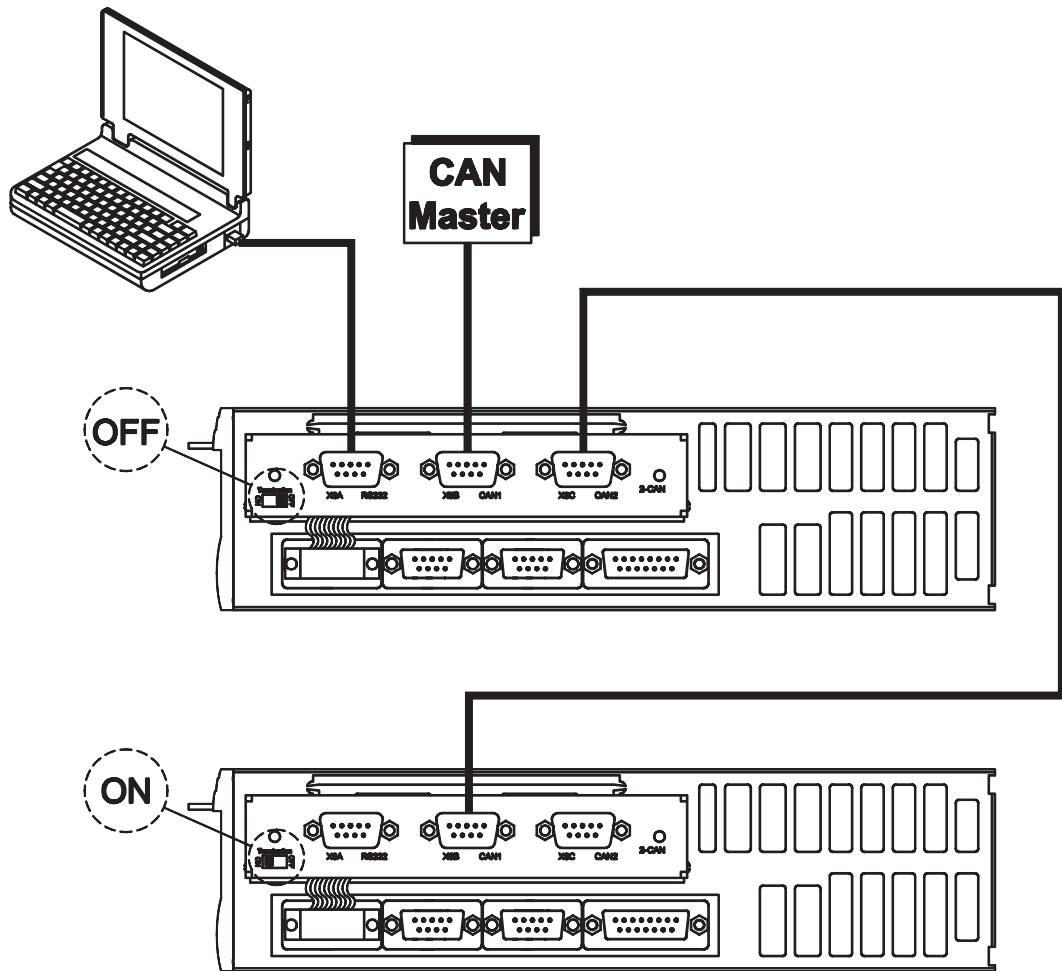

NOTE AGND and DGND (connector X3) must be joined together !

10.3 Special Accessories

10.3.1 Power Supply SINCOS

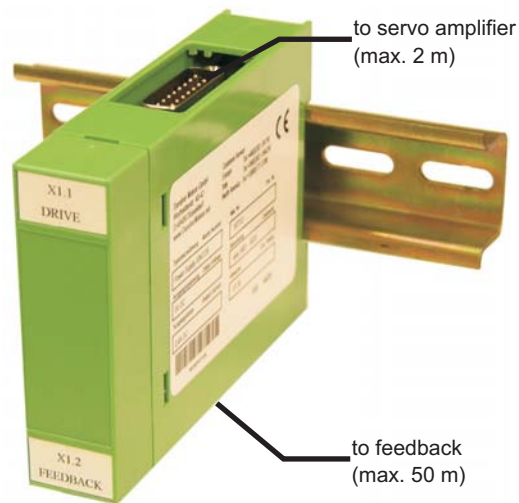

The extended power supply enables the operation of encoder systems at connector X1 with a power consumption of up to 400 mA DC. This power supply is switched between X1 and the encoder and supplied by SERVOSTAR 600.

The connection between the amplifier and the power supply requires a 1:1 protected data cable with a maximum length of 2 m (see ordering information, p. 117ff).

The encoder is connected to the power supply using the normal encoder connection cable (max. 50 m).

Technical Data	
Output voltage	5 V DC (-5%...+5%)
Output current	max. 400 mA DC
Protection type	IP20
Ambient temperature	0...+55°C
Type of mounting	Mounting rail
Cable length (amplifier -> mains supply)	max. 2 m
Cable length (mains supply -> encoder)	max. 50 m

10.3.2 Terminating adapter for encoder cables

Encoders that do not have integrated terminating resistors can be connected to X1 with our standard cables using this adapter (see ordering information p.117ff).

The terminating resistors increase noise immunity. The adapter (approx. 200 mm long) is connected to the servo amplifier (X1).



10.3.3 Hall Dongle

Encoder types that do not provide definitive information on commutation, can be used as a complete feedback system using an additional Hall dongle.

Encoders with analog signals are connected to the dongle, digital encoders are connected to connector X5 on the servo amplifier. Refer to the connection diagram on p. 56.

The connection between the amplifier and the dongle requires a 1:1 protected data cable with a maximum length of 2 m (see ordering information, p. 117ff).

Encoders that require a supply current of more than 150 mA can be operated using the extended power supply "Power Supply SINCOS" (see p.113).

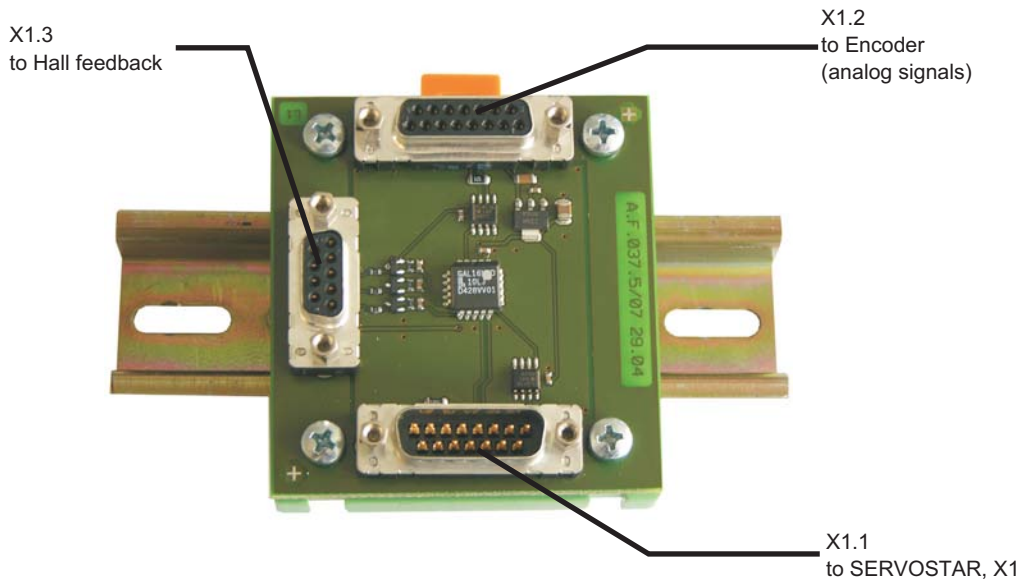

11 Appendix

11.1 Glossary

B	Brake circuit	Converts superfluous energy, which is fed back during braking, into heat in the brake resistor
C	Clock	Clock signal
	Common-mode voltage	The maximum amplitude of a disturbance (on both inputs) which a differential input can eliminate
	Continuous power of brake circuit	Mean power which can be dissipated in the brake circuit
	Counts	Internal count pulses, 1 pulse = $1/2^{20}$ turn ⁻¹
	Current controller	Regulates the difference between the current setpoint and the actual value to 0 Output: power output voltage
D	DC bus link	Rectified and smoothed power voltage
	Disable	Removal of the enable signal (0V or open)
E	Enable	Enable signal for the servo amplifier (+24V)
F	Final speed	Maximum value for speed normalization at $\pm 10V$
	Fieldbus interface	CANopen, PROFIBUS, SERCOS etc.
G	GRAY-code	Special method of representing binary numbers
H	Holding brake	Brake in the motor, which can only be used when the motor is at a standstill
I	I ² t threshold	Monitoring of the actually required r.m.s. current
	Input drift	Temperature and age-dependent alteration of an analog input
	Incremental encoder interface	Position signaling by 2 signals with 90° phase difference, not an absolute position output
	I _{peak} , peak current	The effective value of the peak current
	I _{rms} , effective current	The r.m.s. value of the continuous current
K	K _p , P-gain	Proportional gain of a control loop
L	Limit-switch	Switch limiting the traverse path of the machine; implemented as n.c. (break) contact
M	Machine	The complete assembly of all connected parts or devices, of which at least one is movable
	Monitor output	Output of an analog measurement
	Motion-block	Data packet with all the position control parameters which are required for a motion task
	Multi-axis system	Machine with several independently driven axes
N	Natural convection	Free movement of air for cooling
O	Optocoupler	Optical connection between two electrically independent systems

P	P-controller	Control loop with purely proportional behavior
	Phase shift	Compensation for the lag between the electromagnetic and magnetic fields in the motor
	PID-controller	Control loop with proportional, integral and differential behavior
	PID-T2	Filter time constant for the speed controller output
	Position controller	Regulates the difference between the position setpoint and the actual position to 0 Output : speed setpoint
	Potential isolation	Electrically decoupled
	Power contactor	System protection device with phase monitoring
	Pulse power of the brake circuit	Maximum power which can be dissipated in the brake circuit
R	Regen circuit	see Brake Circuit
	Reset	New start of the microprocessor
	Resolver-digital converter	Conversion of the analog resolver signals into digital information
	Reversing mode	Operation with a periodic change of direction
	Ring core	Ferrite rings for interference suppression
	ROD-Interface	Incremental position output
S	Servo amplifier	Control device for regulating the position of a servomotor
	Setpoint ramps	Limits for the rate of change of the speed setpoint
	Short to ground	Electrically conductive connection between a phase and PE (protective earth (ground))
	Short-circuit	here: electrically conductive connection between two phases
	Speed controller	Regulates the difference between the speed setpoint and the actual value to 0 Output : current setpoint
	SSI-interface	Cyclic-absolute, serial position output
	Supply filter	Device to divert interference on the power supply cables to PE
T	T-tacho, tachometer time constant	Filter time constant in the speed feedback of the control loop
	Tachometer voltage	Voltage proportional to the actual speed
	Thermal control	Temperature-sensitive device built into the motor winding (usually a PTC)
	Tn, I-integration time	Integral section of a control loop
Z	Zero pulse	Output once per turn from incremental encoders, used to zero the machine

11.2 Order numbers

The order numbers of accessories such as cables, brake resistors, mains supplies, etc., can be found in the accessories manual.

11.2.1 Servo amplifiers

Article	EU order code	US order code
SERVOSTAR 601	DE-89700	not available
SERVOSTAR 603	DE-89701	S60300-NA
SERVOSTAR 606	DE-89702	S60600-NA
SERVOSTAR 610	DE-89703	S61000-NA
SERVOSTAR 610-30	DE-102192	S610-3000-NA
SERVOSTAR 614	DE-90846	S61400-NA
SERVOSTAR 620	DE-89704	S62000-NA
SERVOSTAR 601-AS	DE-90350	not available
SERVOSTAR 603-AS	DE-90351	S60301-NA
SERVOSTAR 606-AS	DE-90352	S60601-NA
SERVOSTAR 610-AS	DE-90353	S61001-NA
SERVOSTAR 610-30-AS	DE-102897	S610-3001-NA
SERVOSTAR 614-AS	DE-91448	S61401-NA
SERVOSTAR 620-AS	DE-90354	S62001-NA

*= NA means without built-in expansion card

11.2.2 Expansion cards

Article	EU order code	US order code
Expansion card DeviceNet	DE-103571	OPT-DN
Expansion card PROFIBUS DP	DE-90056	OPT-PB
Expansion card SERCOS	DE-90879	OPT-SE
Expansion card -I/O-14/08-	DE-90057	OPT-EI
Expansion card EtherCAT	DE-108350	OPT-EC
Expansion card SynqNet	DE-200073	OPT-SN
Expansion module 2CAN	DE-101174	not available

11.2.3 Connectors

Article	EU order code	US order code
Connector X3 (I/O)	DE-90061	CON-S6X3
Connector X4 (24V)	DE-90062	CON-S6X4
Connector X0A (Mains)	DE-92258	CON-S6X0A
Connector X0B (Mains)	DE-92259	CON-S6X0B
Connector X7 (DC bus link)	DE-90064	CON-S6X7
Connector X8 (Brake-R)	DE-90065	CON-S6X8
Connector X9 (Motor)	DE-90066	CON-S6X9
Connector X10 (AS)	DE-101696	CON-S6X10
Connector X15 (DeviceNet)	DE-106368	CON-S6X15

11.2.4 Special accessories

Article	EU order code	US order code
Power supply SINCOS	DE-107712	in preparation
HALL Dongle	DE-107351	in preparation
Connection Cable, 1m for X1-Hall Dongle or for X1-Power Supply SINCOS	DE-107730	in preparation
Termination Adapter SINCOS	DE-103692	in preparation

11.3 Repair-/Disposal request Telefax form

To

Kollmorgen Europe GmbH
 Pempelfurtstraße 1
 40880 Ratingen
 Germany

Fax: +49 (0) 2102 9394 3444

Please advise dispatch information for (please select)

- Repair
- Disposal

of these products:

Product	Serial number	Reason ("fault", "return" or similar)

to this address:

Company	
Street	
Zip / Town	
Country	
Specialist Name	
Telephone	
Telefax	
E-Mail	

 City, Date

 Signature

11.4 Index

I	24Vaux. supply, interface	49	M	Mains supply connection, interface.	48
A	Abbreviations	9		Maintenance	17
	Ambient conditions	24		Master-slave	58
	Ambient temperature	24		Motor connector	43
	Analog outputs	66		Motor holding brake	26
	AS-Option	91		Motor, interface	50
	Assembly	36		Mounting position	24
B	Baudrate	84		Multi-axis systems	84
	BISS Interface	53	N	Nameplate	19
	Block diagram (overview)	45		Node address	84
	Brake	26		Noise emission	24
	Brake circuit	27	O	Operating systems	73
	Brake resistor, interface	50		Optical power	104
	BTB/RTO	68		Options	22
C	CANopen-Interface	70		Order numbers	117
	CE conformance	13		Outputs	
	ComCoder interface	56		Analog 1/2	66
	Conductor cross-sections	25		BTB/RTO	68
	Connection diagram	47		DIGI-OUT 1/2	68
D	DC-link interface	49	P	Package supplied	19
	Dimensions	37		Packaging	17
	Disassembling	18		Part number scheme	20
	Disposal	18		PC connection	69
E	Enclosure protection	24		Pin assignments	46
	Encoder emulations	63		Pollution level	24
	Error messages	88		Protection	24
	Expansion card			Pulse-direction, interface	61
	-2CAN-	111	Q	Quickstart Guide	74
	-DeviceNet-	105	R	Repair	18
	-EtherCat-	108		Reparaturanfrage	118
	Guide to installation	98		Resolver, interface	52
	-I/O-14/08-	99		ROD interface	63
	-PROFIBUS-	102		RS232/PC, interface	69
	-SERCOS-	103	S	Safety instructions	11
	-SynqNet-	109		Setpoint inputs	65
	External fusing	24		Setup	71
F	Forming	71		Shielding	
G	Glossary	115		Connection diagram	47
	GOST-R	16		Installation	40
	Ground symbol	41		Shock-hazard protection	34
	Grounding			Sine-cosine encoder, interface	55
	Connection diagram	47		Site	35
	Installation	40		Site altitude	24
H	Hall Dongle	114		SSI, interface	64
	Hardware requirements	73		Standards	8,15
	Holding brake	26		Storage	17
I	Incremental encoder, interface	57		Supply voltage	24
	Inputs			Switch-on and switch-off behavior	29
	Analog setpoints	65		System components, overview	44
	DIGITAL-IN 1/2	67	T	Target group	7
	Enable	67		Technical data	23
	NSTOP	67		Torque, connectors	24
	PSTOP	67		Transport	17
	Installation			Trouble shooting	90
	Expansion cards	98	U	Use as directed	
	Hardware	40		Option AS	92
	Software	73		Servo amplifier	12
K	Key operation	86		Setup software	72
L	LC-Display	86	V	Ventilation	
	Leakage current	34		Installation	35
	LED display	25		Tech.Data	24
	Limit Switch Inputs	67		Vibrations	24
			W	Warning messages	89
				Wiring	40

Service

We are committed to quality customer service. In order to serve in the most effective way, please contact your local sales representative for assistance.
If you are unaware of your local sales representative, please contact the Customer Support.

Europa

Kollmorgen Customer Support Europe

Internet www.kollmorgen.com

E-Mail technik@kollmorgen.com

Tel.: +49 (0)2102 - 9394 - 2250

Fax: +49 (0)2102 - 9394 - 3110

North America

Kollmorgen Customer Support North America

Internet www.kollmorgen.com

E-Mail support@kollmorgen.com

Tel.: +1 - 540 - 633 - 3545

Fax: +1 - 540 - 639 - 4162